

# EPSON

Robot Controller  
RC700 / RC90 Option

*PG Motion System*

Rev.4

EM19XC4128F

Robot Controller RC700 / RC90 Option

PG Motion System Rev.4

Robot Controller RC700 / RC90 Option

# *PG Motion System*

Rev.4

Copyright © 2012-2019 SEIKO EPSON CORPORATION. All rights reserved.

## FOREWORD

Thank you for purchasing our robot products.

This manual is intended for the users who setup and program the PG Motion System.  
Please thoroughly read this and other related manuals prior to and while using this option.

## WARRANTY

The Manipulator and its optional parts are shipped to our customers only after being subjected to the strictest quality controls, tests, and inspections to certify its compliance with our high performance standards.

Product malfunctions resulting from normal handling or operation will be repaired free of charge during the normal warranty period. (Please ask your Regional Sales Office for warranty period information.)

However, customers will be charged for repairs in the following cases (even if they occur during the warranty period):

1. Damage or malfunction caused by improper use which is not described in the manual, or careless use.
2. Malfunctions caused by customers' unauthorized disassembly.
3. Damage due to improper adjustments or unauthorized repair attempts.
4. Damage caused by natural disasters such as earthquake, flood, etc.

### Warnings, Cautions, Usage:

1. If the Manipulator or associated equipment is used outside of the usage conditions and product specifications described in the manuals, this warranty is void.
2. If you do not follow the WARNINGS and CAUTIONS in this manual, we cannot be responsible for any malfunction or accident, even if the result is injury or death.
3. We cannot foresee all possible dangers and consequences. Therefore, this manual cannot warn the user of all possible hazards.

## TRADEMARKS

Microsoft, Windows, and Windows logo are either registered trademarks or trademarks of Microsoft Corporation in the United States and/or other countries. Other brand and product names are trademarks or registered trademarks of the respective holders.

## TRADEMARK NOTATION IN THIS MANUAL

Microsoft® Windows® 7 Operating system

Microsoft® Windows® 8 Operating system

Microsoft® Windows® 10 Operating system

Throughout this manual, Windows 7, Windows 8, and Windows 10 refer to above respective operating systems. In some cases, Windows refers generically to Windows 7, Windows 8, and Windows 10.

## NOTICE

No part of this manual may be copied or reproduced without authorization.

The contents of this manual are subject to change without notice.

Please notify us if you should find any errors in this manual or if you have any comments regarding its contents.

## MANUFACTURER

**SEIKO EPSON CORPORATION**

## CONTACT INFORMATION

Contact information is described in “SUPPLIERS” in the first pages of the following manual:

*Robot System Safety and Installation Read this manual first*

# Before Reading This Manual



This section describes what you should know before reading this manual.

## Safety Precautions

Installation of robots and robotic equipment should only be performed by qualified personnel in accordance with national and local codes. Please carefully read this manual and other related manuals before installing the robot system or before connecting cables. Keep this manual handy for easy access at all times. Please read the Safety chapter in User’s Guide to understand safety requirements before installing the robot system.

## Conventions

Important safety considerations are indicated throughout the manual by the following symbols. Be sure to read the descriptions shown with each symbol.

 WARNING	<ul style="list-style-type: none"> <li>■ This symbol indicates that danger of possible serious injury or death exists if the associated instructions are not followed properly.</li> </ul>
 WARNING	<ul style="list-style-type: none"> <li>■ This symbol indicates that danger of possible harm to people caused by electric shock exists if the associated instructions are not followed properly.</li> </ul>
 CAUTION	<ul style="list-style-type: none"> <li>■ This symbol indicates that a danger of possible harm to people or physical damage to equipment and facilities exists if the associated instructions are not followed properly.</li> </ul>

 CAUTION	<ul style="list-style-type: none"> <li>■ Install a separate hardware piece, an emergency stop circuit for the motor drive that your PG board will be driving (apart from the emergency stop that inputs to the Controller) to securely stop the robot when an emergency stop occurs. The emergency stop input at the Pulse Generating Board is designed to be processed within the software.</li> <li>■ Carefully read the manual for the motor drive you are using and follow both the safety and caution principles.</li> <li>■ Always turn OFF the power before installing or wiring the PG board to the Controller. Installing or wiring the PG board while the power is ON may result in electric shock, abnormal operation of the robot system, and/or malfunction of the Controller and PG board.</li> <li>■ Use extra caution when setting PG robot parameter values. The validity of the data is not completely checked or adjusted. If improper settings are used, the robot may move unexpectedly. The unexpected movement of the robot is extremely hazardous and may cause damage to the robot and/or peripheral equipment.</li> </ul>
--	---

# Control System Configuration

This option is used with the following combinations of Controllers and software.

## TYPE A:

Controller	Software
RC700	EPSON RC+ 7.0

## TYPE B: Robot Controller RC90 with the following label attached.

Label	Controller	Software
	RC90	EPSON RC+ 7.0

		RC90 controller firmware
		Ver.7.0.2.0
EPSON RC+ 7.0	Before Ver.7.0.1	!!!
	Ver.7.0.2 or later	OK

**OK: Compatible** All functions of the EPSON RC+ 7.0 and the Controller are available.

**!!!: Compatible** Connection is OK. We recommend using EPSON RC+7.0 Ver. 7.0.2 or later.

NOTE



This option is not available for Robot Controller RC90 (EPSON RC+ 5.0) without the label.

NOTE



Manual PDF for TYPE B is available from EPSON RC+ 7.0 Ver. 7.0.2





---

<b>1. Getting Started</b>	<b>1</b>
1.1 Introduction .....	1
1.2 System Overview .....	1
1.3 How to Setup and Use the System.....	2
1.3.1 Hardware Setup Overview .....	2
1.3.2 Software Setup Overview.....	2
<b>2. Hardware</b>	<b>3</b>
2.1 PG Board Specifications .....	3
2.2 Part Names and Functions .....	5
2.2.1 Component Names & Locations .....	5
2.2.2 DIP Switch Settings.....	6
2.2.3 Jumper Settings .....	7
2.2.4 Rotary Switch Settings .....	7
2.2.5 LEDs.....	7
2.2.6 Connectors .....	7
2.2.7 Installation in the Controller.....	7
2.3 Internal Circuitry .....	8
2.3.1 Signal Functions .....	8
2.3.2 Input Circuit .....	10
2.3.3 Output Circuit .....	11
2.4 Wiring .....	12
2.4.1 Minimizing Noise Interference.....	12
2.4.2 Connectors .....	13
2.4.3 PG Board Connector Pin Outs .....	14
2.4.4 PG Terminal Block Pin Outs .....	16
2.4.5 Typical Applications.....	18
2.5 Safety Features.....	19
2.5.1 Typical Application of Emergency Stop Circuit.....	20
<b>3. Software</b>	<b>21</b>
3.1 Creating PG Robots in EPSON RC+ .....	21
3.2 PG Robot Configuration.....	23
3.2.1 PG Robot Parameters Overview.....	23
3.2.2 PG Parameters.....	24
3.2.3 PG Parameters joint.....	25
3.2.4 Backup and Restore Parameter Data .....	30
3.3 [Robot Manger] Configuration.....	32

## Table of Contents

---

3.3.1	Overview of [Robot Manager] .....	32
3.3.2	[Range].....	33
3.3.3	[Home Config] .....	33
3.3.4	[Mcal Order] .....	34
3.4	Using PG Robots in EPSON RC+ .....	35
3.4.1	PG Cartesian Robots .....	35
3.4.2	PG Joint Robots .....	35
3.4.3	Tuning .....	35
3.4.4	Motion Commands .....	36
3.4.5	SLock and SFree .....	36
3.4.6	Dry Run .....	36
3.4.7	PG Signal Status Display.....	37
<b>4. Calibration Types</b>		<b>38</b>
<b>5. Troubleshooting</b>		<b>50</b>
<b>6. Maintenance Parts List</b>		<b>54</b>

# 1. Getting Started

## 1.1 Introduction

The PG Motion System option enables you to create robots that use third party drives and motors. PG robots can coexist with and behave similar to standard robots in the EPSON RC+ system. Use PG robots to control auxiliary equipment such as XY tables, slides, rotary axes, etc.

Features include:

One or more PG robots can be used along with standard robots on the same system. (Max. 16 robots in total)

PG robots can be a Cartesian or Joint type.

Both stepper motors and servo motors are supported.

Cartesian type PG robots with 2 or more axes can use Vision Guide.

PG robots are fully integrated into the EPSON RC+ environment and basically operate the same as standard robots.

Safety features include Emergency Stop, Safeguard, over travel limits, and drive alarm.

Before using the PG Motion System option, read through this entire manual.

## 1.2 System Overview

The PG Motion System is a Robot Controller RC700 / RC90 option that includes a software component of EPSON RC+ and one or more Pulse Generator boards. The customer supplies the drives and motors using third party equipment.

The PG Motion System supports up to 4 PG boards for RC700 and 2 PG boards for RC90. Each board has four channels, which allows a total of sixteen joints for RC700 and eight joints for RC90. A PG robot can have from 1 to 4 joints for Cartesian coordinate robot, 1 to 7 joints for the Joint type robot.

Included in this package:

Pulse Generator board (hereinafter referred to as PG board)

PG board label (attached only if the PG board is purchased separately)

PG board connector

(Plug:DX40-100P, Cover:DX-100-CV-1 Hirose Electric Co.,Ltd.)

A PG board cable is available as an optional part. This cable is configured as shown below:

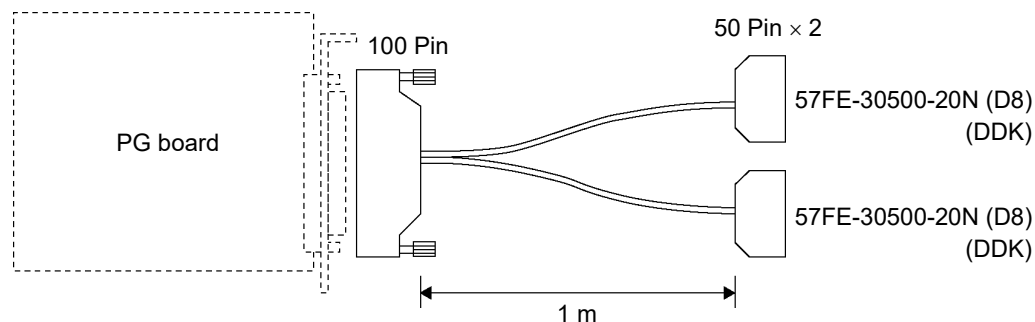

### 1.3 How to Setup and Use the System

The following sections describe the basic steps on how to setup and use the PG Motion System.

#### 1.3.1 Hardware Setup Overview

Refer to *Chapter 2, Hardware* for the following instructions:

- (1) Read the entire Hardware chapter and design the PG hardware for your system. Two examples are provided.
- (2) Configure and install one or more PG boards in the Controller.
- (3) Wire cables for PG boards and drives.

#### 1.3.2 Software Setup Overview

Refer to *Chapter 3, Software* for the following instructions:

- (1) Create one or more PG robots in the EPSON RC+ system configuration.
- (2) Test each PG robot and verify that all safety features are operating properly.
- (3) Write SPEL+ software to control PG robots from your EPSON RC+ applications.

## 2. Hardware

This chapter describes the PG board hardware including the functions, switch settings, and internal circuits of the PG board.

### 2.1 PG Board Specifications

Item	Description
Board Name	H756
Compatible Controller	RC700 / RC90
Expansion Capability	RC700: 4 boards maximum / RC90: 2 boards maximum
Control Axes	4 axes per board
Target Motor	Either servo motors or stepper motors can be used.
Output Pulse Rate	0.1 pps to 6.5 Mpps
Speed Setting	100 steps in the program with the flexible maximum speed setting. The calibration speed can be programmed separately from the normal operation speeds.
Acceleration Settings	The program provides 100 steps each for Acceleration and Deceleration. (The maximum acceleration or maximum deceleration setting can be changed.)
Arm Travel Range [pulse]	– 2,147,483,647 to 2,147,483,647 (32 bits)
Pulse Output Type	Selectable in software: Pulse / Direction Output Method or CW / CCW Pulse Output Method
Rotating Direction	Programmable in the software.
Positioning Method	The $\overline{\text{DEND}}$ (detection-end) signal generated from the servo drive (when a servo drive is used).
Calibration	Selectable from the seven (7) calibration types in the software.
Stop Function	The pulse generation to be stopped at the input of either the limit or alarm signal.
S-curved Acceleration/Deceleration	Selectable in software
Continuous Rotation	Selectable in software
Relative Quantity Travel	Selectable in software

## 2. Hardware

Item	Description
Output Signal	Counter reset ( $\overline{\text{DRST}}$ ) signal
Input Signal	<ul style="list-style-type: none"> <li>- Origin signal (<math>\overline{\text{ORG}}</math>). Normally open.</li> <li>- Near-to-origin signal (<math>\overline{\text{NORG}}</math>). Normally open.</li> <li>- CW limit signal (CWLM). Normally closed.</li> <li>- CCW limit signal (CCWLM). Normally closed.</li> <li>- Alarm signal (ALM)</li> <li>- Encoder Phase -Z signal (ZORG)</li> <li>- Detection-end signal (<math>\overline{\text{DEND}}</math>)</li> </ul>
Safety Features	<p>The following safety features of Robot Controller RC700 / RC90 are supported:</p> <ul style="list-style-type: none"> <li>- Emergency Stop Input</li> <li>- Safeguard Input</li> <li>- Enable SW Input</li> <li>- Low/High Power Mode</li> </ul>
Board Address	Set by DIP switches on the board.
I/F Connector on the Board	DX10A-100S (Hirose Electric Co.,Ltd.)
Power Supply	<p>5 V <math>\pm 5\%</math> 1.0 A (max.)            24 V <math>\pm 2\%</math> 200 mA (max.)            (from the external power source)</p>
PG Robot Limitations	Refer to the section 3.4 <i>Using PG robots in EPSON RC+</i>

## 2.2 Part Names and Functions

### 2.2.1 Component Names & Locations

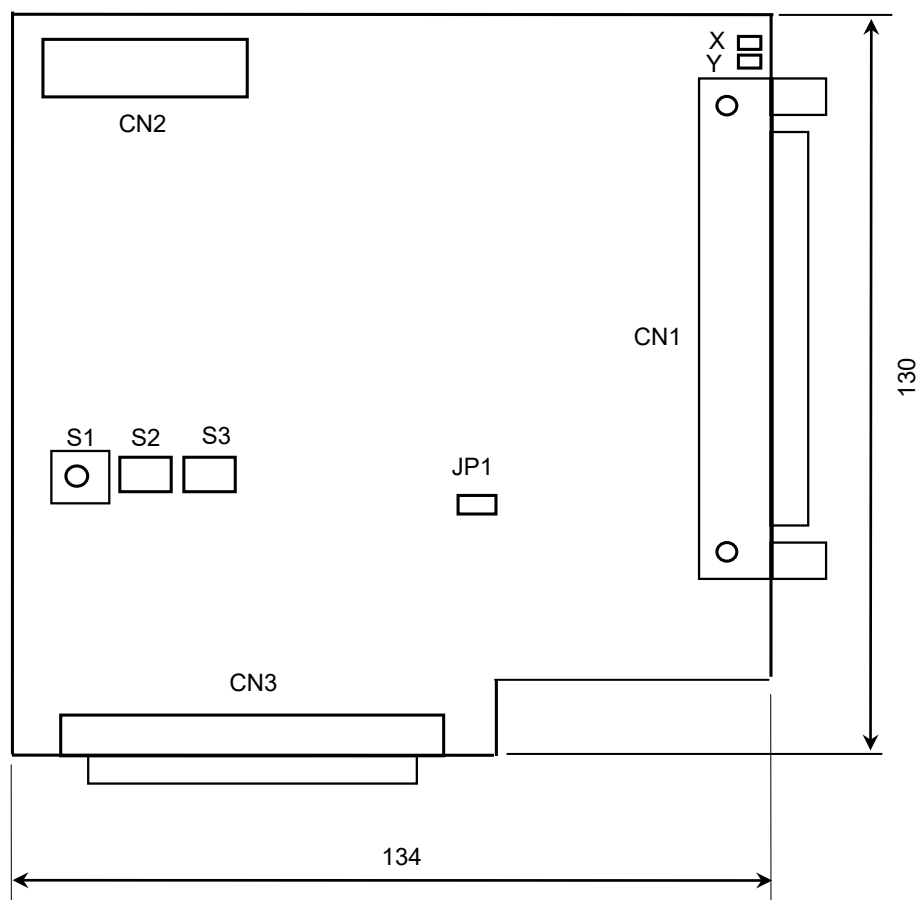

Rotary switch	: S1
DIP Switch	: S2, S3
LED	: X, Y
Jumpers	: JP1
Connectors	: CN1, CN2, CN3

### 2.2.2 DIP Switch Settings

The board number is set by DIP switch (S2, S3) on the PG board.

The first PG board must be set as shown below:

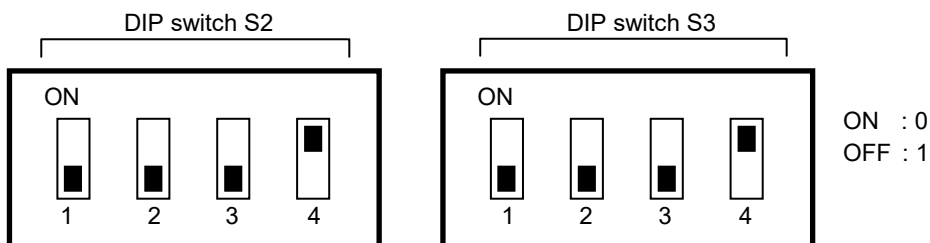

The second PG board must be set as shown below:

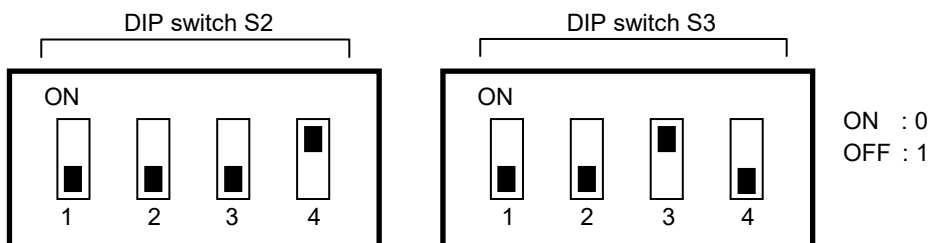

The third PG board must be set as shown below:

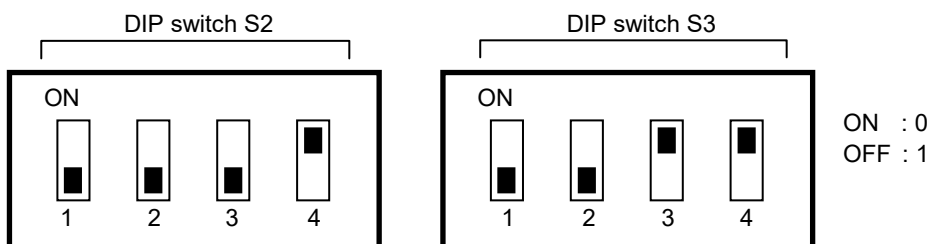

The fourth PG board must be set as shown below:

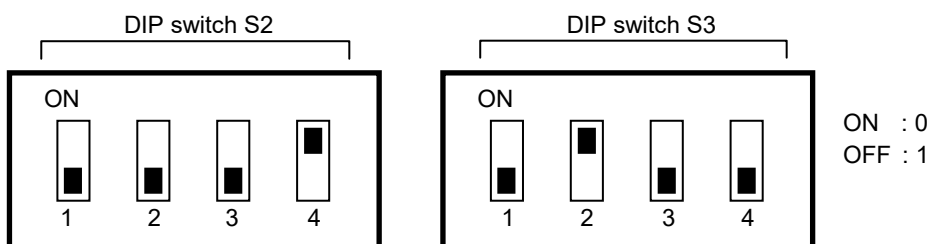

If you purchased the PG board alone, apply the provided board number seal to the board panel before installing to the controller and be sure to keep a written record of the board number.

If the board has been already installed before shipment, the board number is properly configured and there is no need of your further configuration.



If you use the PG board for the conveyor tracking, use another address for the PG board of the PG motion system. For example, if the PG board 1 is used for the conveyor tracking, then use the PG board 2 for the PG motion system.



### 2.2.3 Jumper Settings

Do not change the jumper settings. At shipment, it is set as below:

JP1 : with jumpers

### 2.2.4 Rotary switch Settings

Do not change the Rotary switch S1 settings. At shipment, it is set as below:

S1 : Position of 1

### 2.2.5 LEDs

The LEDs on the board are used to monitor the following signals:

X, Y : Inside status of each axis. Turns ON when ready to receive a command.

### 2.2.6 Connectors

CN1 : Connection for the external devices  
(Refer to the section 2.3 Internal Circuitry for further details.)

CN2 : Unused

CN3 : Connector for internal connection

### 2.2.7 Installation in the Controller

Turn OFF the Controller.

Remove the open slot panel at the front of the Controller. Install the PG board and secure it with screws. For details, refer to the instruction sheet attached to the board.

Once the board is installed, refer to the section *3.1 Creating PG Robots in EPSON RC+* for software installation and settings.

## 2.3 Internal Circuitry

### 2.3.1 Signal Functions

The table below describes the function of each PG board signal.

Direction	Signal Name	Function	Description
Output	+COM	+COMMON for CWP and CCWP	Outputs the +5V power source for the CWP and CCWP signals.
	+DRSTCOM	+COMMON for $\overline{\text{DRST}}$	Outputs +5V for $\overline{\text{DRST}}$ signal.
	$\overline{\text{CWP}}$ $\overline{\text{CWP}}$	Outputs CW pulses	Generates the pulse train for the CW direction when the Pulse Output parameter is set to CW/CCW. Generates the pulse train when the Pulse Output parameter is set to Pulse / Direction.
	$\overline{\text{CCWP}}$ $\overline{\text{CCWP}}$	Outputs CCW pulses	Generates the pulse train for the CCW direction when the Pulse Output parameter is set to CW/CCW. Generates the direction signal when the Pulse Output parameter is set to Pulse / Direction (clockwise when the $\overline{\text{CCWP}}$ is low).
	$\overline{\text{DRST}}$	Drive reset signal	Outputs a signal to reset the drive's deviation counter. If the pulse output is put into a rapid stop, the $\overline{\text{DRST}}$ signal = Low is output for 10 ms. Must be disconnected when a stepper motor is used.
	$\overline{\text{SVON}}$	Servo ON signal	Outputs the servo ON signal when connecting the PG board to the servo drive. Must be left disconnected when a stepper motor is used. The signal is OFF when controller is launched. It turns OFF automatically when any one of the joints within a manipulator indicates either a servo error or limit switch related errors.

Direction	Signal Name	Function	Description
Input	CWLM	CW (clockwise) Limit signal	Connect to normally closed CW Limit switch. This signal is accepted only when clockwise (CW) pulses are generated. When this signal is detected, the pulse generation will be stopped either gradually or immediately according to the software setting.
	CCWLM	CCW (counter-clockwise) Limit signal	Connect to normally closed CCW Limit switch. This signal is accepted only when counter-clockwise (CCW) pulses are generated. When this signal is detected, the pulse generation will be stopped either gradually or immediately according to the software setting.
	$\overline{\text{NORG}}$	Near-to-Origin signal	Connect to either a photo or magnetic normally open sensor to detect the proximity of the target origin. Ensure that the proximity sensor is always used with an origin sensor (either ORG or Z-Phase). If a mechanical switch is used, you may need to connect a capacitor in parallel with the switch (0.1 $\mu$ f 50V recommended).
	$\overline{\text{ORG}}$	Origin signal	If the motor encoder Z-Phase signal will not be used, connect either a photo or magnetic normally open sensor to detect the target origin. Leave the ZORG terminal unconnected. The accuracy of calibration or positioning can be increased and the calibration time can be shortened by using the origin sensor with a proximity sensor (NORG). If a mechanical switch is used, you may need to connect a capacitor in parallel with the switch (0.1 $\mu$ f 50V recommended).
	+ZORG -ZORG	Encoder Phase -Z signal	Use this terminal if the motor encoder's Z-Phase is used as an origin sensor in which case the ORG terminal must be left disconnected.
	$\overline{\text{DEND}}$	Detection (calibration) end signal	Connect to the signal from the drive that indicates that positioning is complete. Must be left disconnected if a stepper motor is used.
	ALM	Alarm signal	Connect the alarm signal from the drive. Generation of pulses will be stopped gradually or immediately when this signal is detected. The alarm logic and the stop mode are defined in the software.

## NOTE



For DEND input, when a servo motor is used, the position complete signal from the drive must be connected. After a MOVE command is executed, SPEL waits until the DEND input is activated. When the DEND input is not activated even after waiting for a time specified by a FINE command, a message "Error 4004: Event waiting error with the Motion Control Module." appears. In case of this error, it is necessary to exit controller, stop the SPEL Runtime Drivers, then restart controller.

When it is expected that your servo drive does not have an output equivalent to the positioning completion signal, or that the DEND input is not activated, the DEND input must be connected to GND. In this case, SPEL does not check that the servo drive's positioning is completed. Therefore, after the operation command is executed, use the time delay necessary for positioning to be complete in your application.

### 2.3.2 Input Circuit

ORG(Origin), NORG(Near-to-origin), DEND(Detection-end), ALM(Alarm)

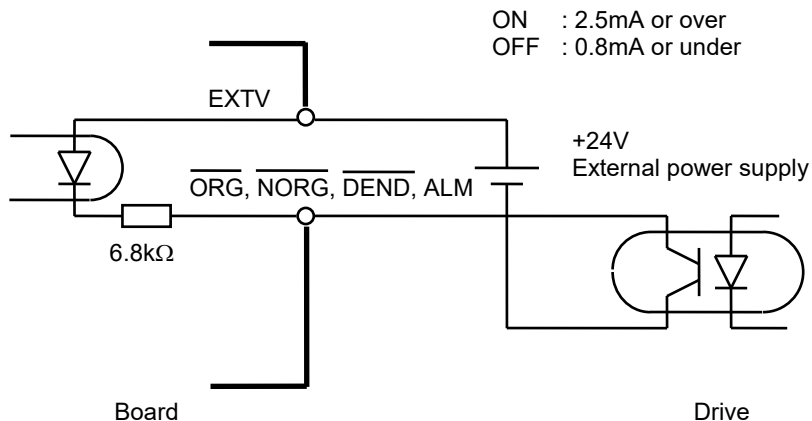

The DEND terminal must be left disconnected if a stepper motor is used.  
The input logic of the Alarm signal can be changed in the software.

### CWLM(CW Limit), CCWLM(CCW Limit)

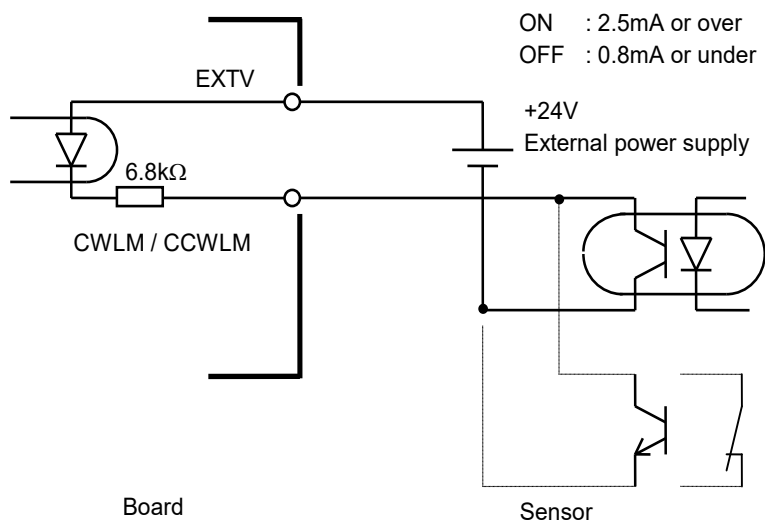

The CWLIM and CCWLIM limit switches must be normally closed. The ORG and NORG switches must be normally open.

### ZORG (Encoder Phase -Z) Signal

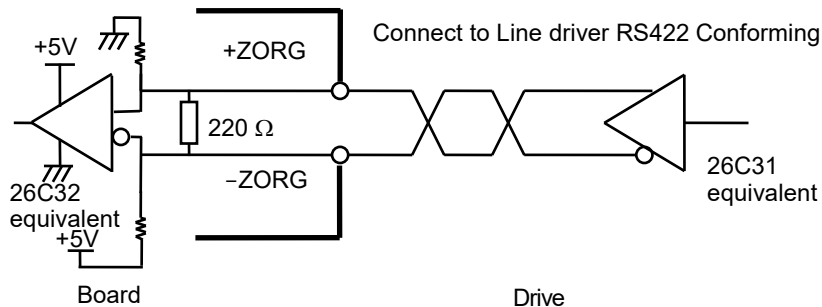

This terminal must be connected when an Encoder Z Phase signal is used as the origin signal.

2.3.3 Output Circuit

CWP (CW Pulse Output)/ CCWP (CCW Output) Signals

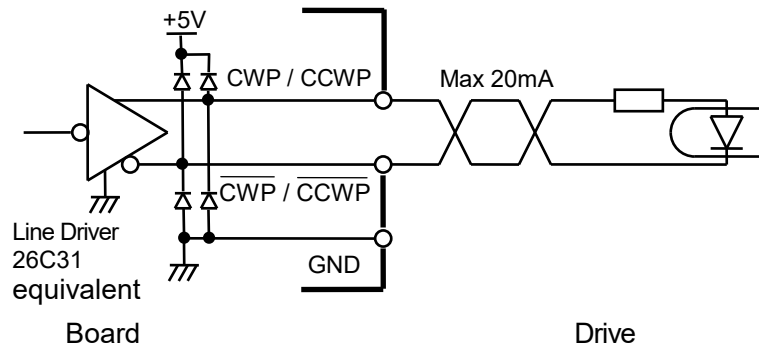

DRST (Drive Reset)

The DRST terminal does not need to be connected when a stepper motor is used.

When the servo driver counter reset input is +5V interface, refer to the connection example below.

If the current-limiting resistor of the driver is less than 150Ω, provide an external resistor to ensure 150Ω or more.

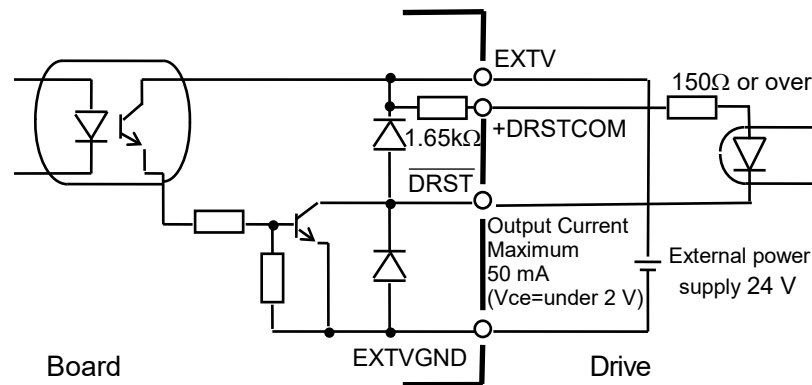

When the servo driver counter reset input is +24V interface, refer to the connection example below.

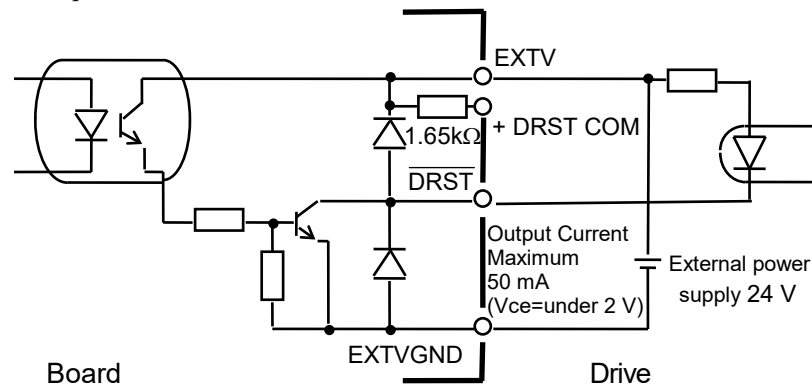

## SVON(Servo ON)

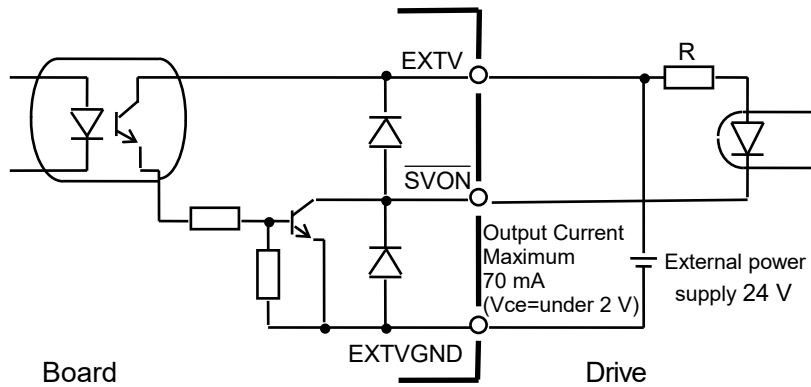

## 2.4 Wiring

## 2.4.1 Minimizing Noise Interference

Follow guidelines listed below when connecting a PG board to a drive:

Minimize noise interference by using the wiring recommendations as described in the drive manual.

Use a noise filter on the primary power supply for EXT V/EXT V GND and separate between the primary and secondary wiring by at least 200mm.

For EXT V/EXT V GND and the instruction signals for using twisted pair (as indicated in the circuit diagram in the previous “Input and Output Circuits”), be sure to use twisted pair cables.

Use shielded twisted pair cable for connecting the PG board to the drive.

Follow the drive manual and the manufacturer’s instructions for shielding.

Keep the wiring between the PG board and drive as short as possible (within 1.5 m) and position them to be separated from possible noise sources as much as possible.

For the load to be used in the controller’s (Control Unit’s) I/O, whether a relay or solenoid, make sure to use one with surge suppressor. Install a diode (or such) on the Load L side where there is no surge suppressor.

For such peripheral equipment as a conveyor, switching the rotating direction (start, forward, reverse) of an AC motor (an induction motor, a 3-phase induction motor, etc.) requires an appropriate spark suppressor between lines. The closer the suppressor is to the motor, the more effective the noise suppression.

## 2.4.2 Connectors

The table below lists the connectors on the PG board and the compatible connectors for wiring:

Receptacle on the Board		DX10A-100S (manufacturer: Hirose Electric Co., Ltd.)
Wiring Plug Connectors	Individually pressed-in type	DX30-100P (for AWG#30) DX30A-100P (for AWG#28)
	Pressed-in-as-a-whole type	DX31-100P (for AWG#30) DX31A-100P (for AWG#28)
	Soldered type	DX40-100P
Connector for Wiring to the Cover		DX30M-100-CV1

If you are using the optional cable, refer to section *2.4.4 PG Terminal Block Pin Outs* later in this chapter.

### 2.4.3 PG Board Connector Pin Outs

The pin outs for the PG board connector (DX10A-100S) are shown in the following table. For details of each signal, refer to section 2.3.1 *Signal Functions*. If you are using the optional cable, refer to section 2.4.4 *PG Terminal Block Pin Outs* later in this chapter.

Pin	Dir	Signal	Description	Pin	Dir	Signal	Description
1	In	CWLM1	CW limit signal for Axis #1 (*2)	51	In	CWLM3	CW limit signal for Axis #3 (*2)
2	In	CCWLM1	CCW limit signal for Axis #1 (*2)	52	In	CCWLM3	CCW limit signal for Axis #3 (*2)
3	In	$\overline{\text{NORG1}}$	Near-to-origin signal for Axis #1	53	In	$\overline{\text{NORG3}}$	Near-to-origin signal for Axis #3
4	In	$\overline{\text{ORG1}}$	Origin signal for Axis #1 (*1)	54	In	$\overline{\text{ORG3}}$	Origin signal for Axis #3 (*1)
5	In	CWLM2	CW limit signal for Axis #2 (*2)	55	In	CWLM4	CW limit signal for Axis #4 (*2)
6	In	CCWLM2	CCW limit signal for Axis #2 (*2)	56	In	CCWLM4	CCW limit signal for Axis #4 (*2)
7	In	$\overline{\text{NORG2}}$	Near-to-origin signal for Axis #2	57	In	$\overline{\text{NORG4}}$	Near-to-origin signal for Axis #4
8	In	$\overline{\text{ORG2}}$	Origin signal for Axis #2 (*1)	58	In	$\overline{\text{ORG4}}$	Origin signal for Axis #4 (*1)
9	–	–	Not used	59	–	–	Not used
10	In	ALM1	Alarm input signal for Axis #1	60	Out	$\overline{\text{SVON1}}$	Servo ON output signal for Axis #1
11	In	ALM2	Alarm input signal for Axis #2	61	Out	$\overline{\text{SVON2}}$	Servo ON output signal for Axis #2
12	In	ALM3	Alarm input signal for Axis #3	62	Out	$\overline{\text{SVON3}}$	Servo ON output signal for Axis #3
13	In	ALM4	Alarm input signal for Axis #4	63	Out	$\overline{\text{SVON4}}$	Servo ON output signal for Axis #4
14	In	EXTV	External power supply for Input circuit	64	In	EXTVGND	External power supply GND for Input circuit
15	In	EXTV	External power supply for Input circuit	65	In	EXTVGND	External power supply GND for Input circuit
16	Out	+COM	CWP1, CCWP1 +COMMON	66	Out	+COM	CWP3, CCWP3 +COMMON
17	Out	CWP1	CW pulse output signal for Axis #1	67	Out	CWP3	CW pulse output signal for Axis #3
18	Out	$\overline{\text{CWP1}}$	Inverted CW pulse output for Axis #1	68	Out	$\overline{\text{CWP3}}$	Inverted CW pulse output for Axis #3
19	Out	CCWP1	CCW pulse output for Axis #1	69	Out	CCWP3	CCW pulse output for Axis #3
20	Out	$\overline{\text{CCWP1}}$	Inverted CCW pulse output for Axis #1	70	Out	$\overline{\text{CCWP3}}$	Inverted CCW pulse output for Axis #3
21	Out	$\overline{\text{+DRST COM1}}$	$\overline{\text{DRST1}}$ +COMMON	71	Out	$\overline{\text{+DRST COM3}}$	$\overline{\text{DRST3}}$ +COMMON
22	Out	$\overline{\text{DRST1}}$	Drive Reset signal for Axis #1	72	Out	$\overline{\text{DRST3}}$	Drive Reset signal for Axis #3
23	In	$\overline{\text{DEND1}}$	Detection End signal for Axis #1	73	In	$\overline{\text{DEND3}}$	Detection End signal for Axis #3
24	–	–	Not used	74	–	–	Not used
25	–	–	Not used	75	–	–	Not used



Pin	Dir	Signal	Description	Pin	Dir	Signal	Description
26	-	-	Not used	76	-	-	Not used
27	-	-	Not used	77	-	-	Not used
28	-	-	Not used	78	-	-	Not used
29	In	+ZORG1	Encoder Phase +Z signal for Axis #1	79	In	+ZORG3	Encoder Phase +Z signal for Axis #3
30	In	-ZORG1	Encoder Phase -Z signal for Axis #1	80	In	-ZORG3	Encoder Phase -Z signal for Axis #3
31	-	-	Not used	81	-	-	Not used
32	Out	+COM	CWP2, CCWP2 +COMMON	82	Out	+COM	CWP4, CCWP4 +COMMON
33	Out	CWP2	CW pulse output for Axis #2	83	Out	CWP4	CW pulse output for Axis #4
34	Out	$\overline{\text{CWP2}}$	Inverted CW pulse output for Axis #2	84	Out	$\overline{\text{CWP4}}$	Inverted CW pulse output for Axis #4
35	Out	CCWP2	CCW pulse output for Axis #2	85	Out	CCWP4	CCW pulse output for Axis #4
36	Out	$\overline{\text{CCWP2}}$	Inverted CCW pulse output for Axis #2	86	Out	$\overline{\text{CCWP4}}$	Inverted CCW pulse output for Axis #4
37	Out	+DRST COM2	$\overline{\text{DRST2}}$ +COMMON	87	Out	+DRST COM4	$\overline{\text{DRST4}}$ +COMMON
38	Out	$\overline{\text{DRST2}}$	Drive Reset signal for Axis #2	88	Out	$\overline{\text{DRST4}}$	Drive Reset signal for Axis #4
39	In	$\overline{\text{DEND2}}$	Detection End signal for Axis #2	89	In	$\overline{\text{DEND4}}$	Detection End signal for Axis #4
40	-	-	Not used	90	-	-	Not used
41	-	-	Not used	91	-	-	Not used
42	-	-	Not used	92	-	-	Not used
43	-	-	Not used	93	-	-	Not used
44	-	-	Not used	94	-	-	Not used
45	In	+ZORG2	Encoder Phase +Z signal for Axis #2	95	In	+ZORG4	Encoder Phase +Z signal for Axis #4
46	In	-ZORG2	Encoder Phase -Z signal for Axis #2	96	In	-ZORG4	Encoder Phase -Z signal for Axis #4
47	-	-	Not used	97	-	-	Not used
48	-	-	Not used	98	-	-	Not used
49	-	-	Not used	99	-	-	Not used
50	-	GND	Ground	100	-	GND	Ground

- (\*1) Leave this terminal disconnected if you use Encoder Z Phase signal as the origin signal when a servo motor is used.
- (\*2) When the status of the limit signal is OFF (the photo coupler in the input circuit is OFF), the axis is deemed to be out of the Permissible Working Range and pulse generation will be stopped. Therefore, you must connect to an external power source so that the limit signal(s) will remain ON when your system configuration does not use limit signals.

2.4.4 PG Terminal Block Pin Outs

When the optional cable is used, 2 terminal blocks are provided. Pin outs for these terminal blocks are shown in the following two tables. The pin numbers in parentheses are the pins on the PG board connector. For details of each signal, refer to the section 2.3.1 *Signal Functions*.

PG Terminal Block 1

Pin	Signal	Description	Pin	Signal	Description
1 (16)	+COM	CWP1,CCWP1 +COMMON	26 (32)	+COM	CWP2, CCWP2 +COMMON
2 (17)	CWP1	CW pulse output signal for Axis #1	27 (33)	CWP2	CW pulse output for Axis #2
3 (18)	$\overline{\text{CWP1}}$	Inverted CW pulse output for Axis #1	28 (34)	$\overline{\text{CWP2}}$	Inverted CW pulse output for Axis #2
4 (19)	CCWP1	CCW pulse output for Axis #1	29 (35)	CCWP2	CCW pulse output for Axis #2
5 (20)	$\overline{\text{CCWP1}}$	Inverted CCW pulse output for Axis #1	30 (36)	$\overline{\text{CCWP2}}$	Inverted CCW pulse output for Axis #2
6 (21)	+ DRST COM1	$\overline{\text{DRST1}}$ +COMMON	31 (37)	+ DRST COM2	$\overline{\text{DRST2}}$ +COMMON
7 (22)	$\overline{\text{DRST1}}$	Drive Reset signal for Axis #1	32 (38)	$\overline{\text{DRST2}}$	Drive Reset signal for Axis #2
8 (23)	$\overline{\text{DEND1}}$	Detection End signal for Axis #1	33 (39)	$\overline{\text{DEND2}}$	Detection End signal for Axis #2
9 (24)	-	Not used	34 (40)	-	Not used
10 (25)	-	Not used	35 (41)	-	Not used
11 (26)	-	Not used	36 (42)	-	Not used
12 (27)	-	Not used	37 (43)	-	Not used
13 (28)	-	Not used	38 (44)	-	Not used
14 (29)	+ZORG1	Encoder Phase +Z signal for Axis #1	39 (45)	+ZORG2	Encoder Phase +Z signal for Axis #2
15 (30)	-ZORG1	Encoder Phase -Z signal for Axis #1	40 (46)	-ZORG2	Encoder Phase -Z signal for Axis #2
16 (31)	-	Not used	41 (47)	-	Not used
17 (48)	-	Not used	42 (49)	-	Not used
18 (9)	-	Not used	43 (50)	GND	Ground
19 (60)	$\overline{\text{SVON1}}$	Servo ON output signal for Axis #1	44 (61)	$\overline{\text{SVON2}}$	Servo ON output signal for Axis #2
20 (10)	ALM1	Alarm input signal for Axis #1	45 (11)	ALM2	Alarm input signal for Axis #2
21 (1)	CWLM1	CW limit signal for Axis #1	46 (5)	CWLM2	CW limit signal for Axis #2
22 (2)	CCWLM1	CCW limit signal for Axis #1	47 (6)	CCWLM2	CCW limit signal for Axis #2
23 (3)	$\overline{\text{NORG1}}$	Near-to-origin signal for Axis #1	48 (7)	$\overline{\text{NORG2}}$	Near-to-origin signal for Axis #2
24 (4)	$\overline{\text{ORG1}}$	Origin signal for Axis #1	49 (8)	$\overline{\text{ORG2}}$	Origin signal for Axis #2
25 (14)	EXTV	External power supply for Input circuit	50 (64)	EXTVGND	External power supply GND for Input circuit

## PG Terminal Block 2

Pin	Signal	Description	Pin	Signal	Description
1 (66)	+COM	CWP3, CCWP3 +COMMON	26 (82)	+COM	CWP4, CCWP4 +COMMON
2 (67)	CWP3	CW pulse output signal for Axis #3	27 (83)	CWP4	CW pulse output for Axis #4
3 (68)	$\overline{\text{CWP3}}$	Inverted CW pulse output for Axis #3	28 (84)	$\overline{\text{CWP4}}$	Inverted CW pulse output for Axis #4
4 (69)	CCWP3	CCW pulse output for Axis #3	29 (85)	CCWP4	CCW pulse output for Axis #4
5 (70)	$\overline{\text{CCWP3}}$	Inverted CCW pulse output for Axis #3	30 (86)	$\overline{\text{CCWP4}}$	Inverted CCW pulse output for Axis #4
6 (71)	+ DRST COM3	$\overline{\text{DRST3}}$ +COMMON	31 (87)	+ DRST COM4	$\overline{\text{DRST4}}$ +COMMON
7 (72)	$\overline{\text{DRST3}}$	Drive Reset signal for Axis #3	32 (88)	$\overline{\text{DRST4}}$	Drive Reset signal for Axis #4
8 (73)	$\overline{\text{DEND3}}$	Detection End signal for Axis #3	33 (89)	$\overline{\text{DEND4}}$	Detection End signal for Axis #4
9 (74)	-	Not used	34 (90)	-	Not used
10 (75)	-	Not used	35 (91)	-	Not used
11 (76)	-	Not used	36 (92)	-	Not used
12 (77)	-	Not used	37 (93)	-	Not used
13 (78)	-	Not used	38 (94)	-	Not used
14 (79)	+ZORG3	Encoder Phase +Z signal for Axis #3	39 (95)	+ZORG4	Encoder Phase +Z signal for Axis #4
15 (80)	-ZORG3	Encoder Phase -Z signal for Axis #3	40 (96)	-ZORG4	Encoder Phase -Z signal for Axis #4
16 (81)	-	Not used	41 (97)	-	Not used
17 (98)	-	Not used	42 (99)	-	Not used
18 (59)	-	Not used	43 (100)	GND	Ground
19 (62)	$\overline{\text{SVON3}}$	Servo ON output signal for Axis #3	44 (63)	$\overline{\text{SVON4}}$	Servo ON output signal for Axis #4
20 (12)	ALM3	Alarm input signal for Axis #3	45 (13)	ALM4	Alarm input signal for Axis #4
21 (51)	CWLM3	CW limit signal for Axis #3	46 (55)	CWLM4	CW limit signal for Axis #4
22 (52)	CCWLM3	CCW limit signal for Axis #3	47 (56)	CCWLM4	CCW limit signal for Axis #4
23 (53)	$\overline{\text{NORG3}}$	Near-to-origin signal for Axis #3	48 (57)	$\overline{\text{NORG4}}$	Near-to-origin signal for Axis #4
24 (54)	$\overline{\text{ORG3}}$	Origin signal for Axis #3	49 (58)	$\overline{\text{ORG4}}$	Origin signal for Axis #4
25 (15)	EXTV	External power supply for Input circuit	50 (65)	EXTVGND	External power supply GND for Input circuit

2.4.5 Typical Applications

Example of connection with the servo motor driver

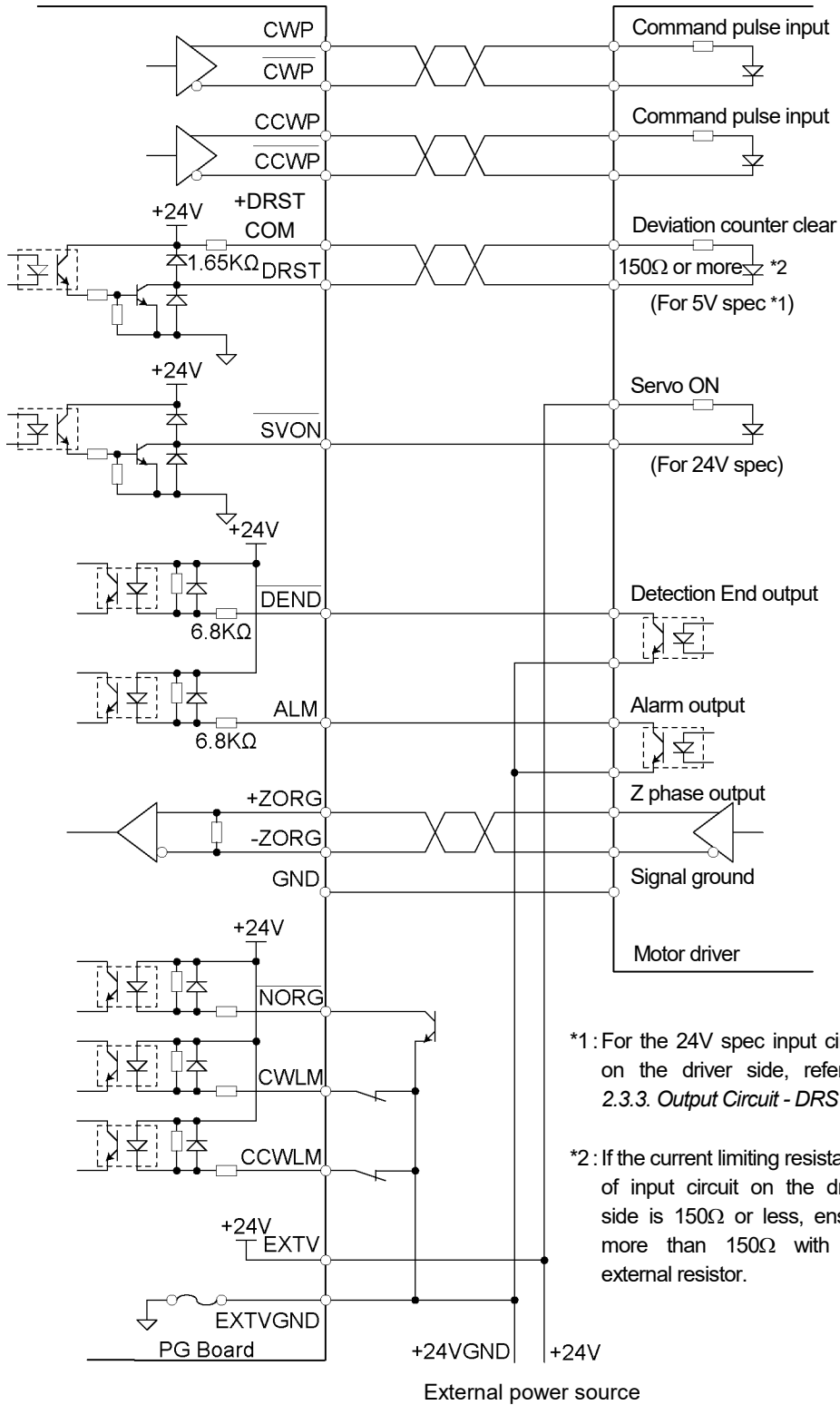

## 2.5 Safety Features

The PG Motion System supports the same safety features as for standard robots. The following table describes how each system safety feature is supported for PG robots.

Safety Features	Supported Function on the PG Board
Emergency Stop Input	Stop generating pulse gradually (by decelerating) or rapidly. You may select either of the two patterns in the software. This emergency stop function is supported only by the software. Emergency stop must also be supported in hardware also. Make sure to install an additional circuit for the purpose of stopping the motor physically in case of emergency. Refer to the sample circuit diagram on the next page in which the motor drive power is turned OFF at the input of Emergency Stop signal to the Controller. For more details, refer to the Robot Controller manual.
Safety Door Input	The function of this input is same as for a standard robot.
High/Low Power Mode	The function of this mode is same as for a standard robot. The acceleration/deceleration is set as follows for the Low Power and High Power state respectively: <ul style="list-style-type: none"> <li>Low Power : Acceleration and deceleration will be limited. The acceleration and deceleration value of default are fixed as follows:               <ul style="list-style-type: none"> <li>Acceleration : 10%</li> <li>Deceleration : 5%</li> </ul> </li> <li>High Power : The maximum speed, acceleration and deceleration will be operable at the set-up maximum value in the software.</li> </ul>
Enable Switch Input	The function of this input is same as for a standard robot.
Mode Switch Input	The function of this input is same as for a standard robot.

For more Safety Features, refer to the Robot Controller manual or the *Safety Chapter* in the EPSON RC+ User's Guide.

### 2.5.1 Typical Application of Emergency Stop Circuit

Connecting external safety relay

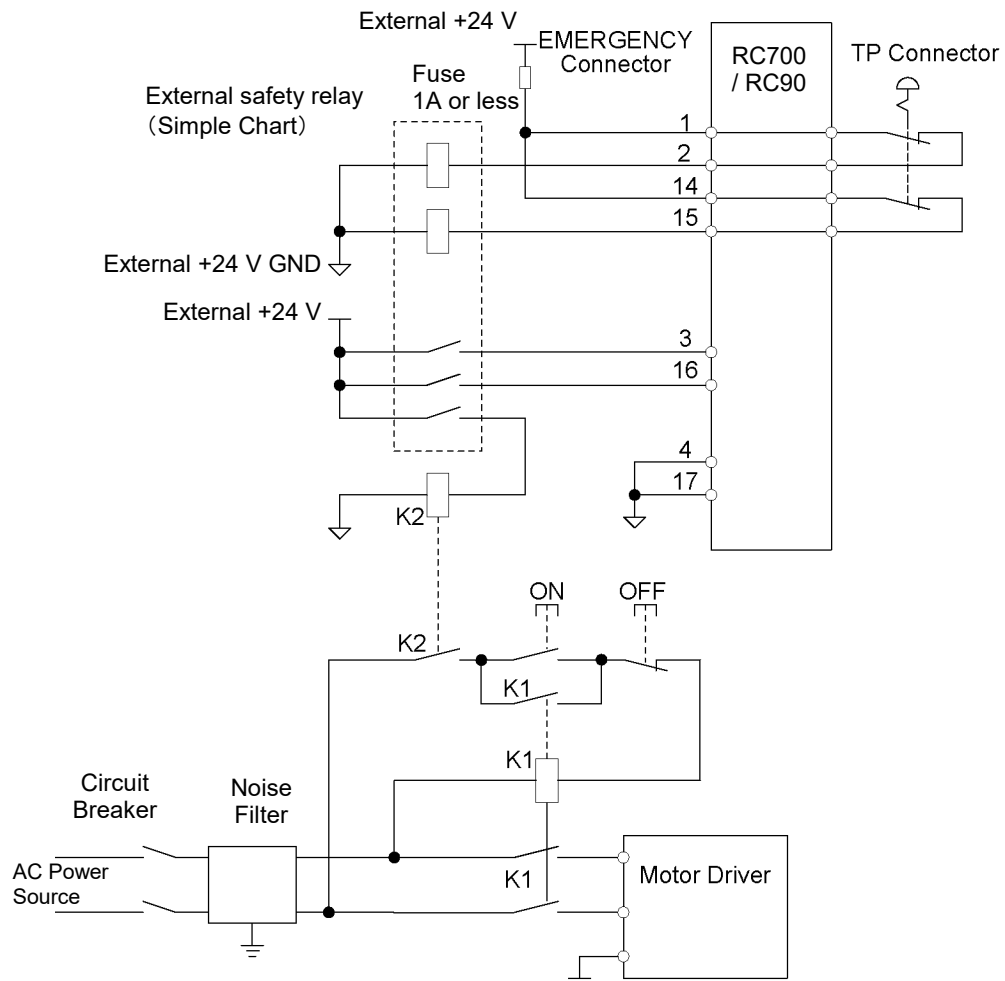

CAUTION

- Always take anti-surge measures for coils (electromagnetic contactors, relays, etc.) or contacts. If anti-surge measures are not taken, a reverse current may flow. The reverse current may cause damage to peripheral equipment.

## 3. Software

This chapter describes the software setup to use the PG Motion System.

### 3.1 Creating PG Robots in EPSON RC+

The PG Motion System can control up to four axes per PG board, so there can be from one to four PG robots per board, depending on the number of axes per robot.



If you are also using PG boards for Conveyor Tracking in the same system, those boards are only used for conveyor tracking encoders. PG boards used for the PG Motion System are used separately, but are enumerated in the system along with the PG boards used for conveyor tracking. If you add a PG board to the system for use with the motion system and there is already one or more boards used for conveyor tracking, then the PG board # will be the next board after the conveyor tracking PG boards. For example, if you add 1 PG board for conveyor tracking, and then add a board for PG motion, that board will be #2.

To create a PG robot in EPSON RC+, follow these steps:

- (1) Turn on the Controller and launch EPSON RC+.
- (2) Select [Setup] - [System Configuration]-[Robots].

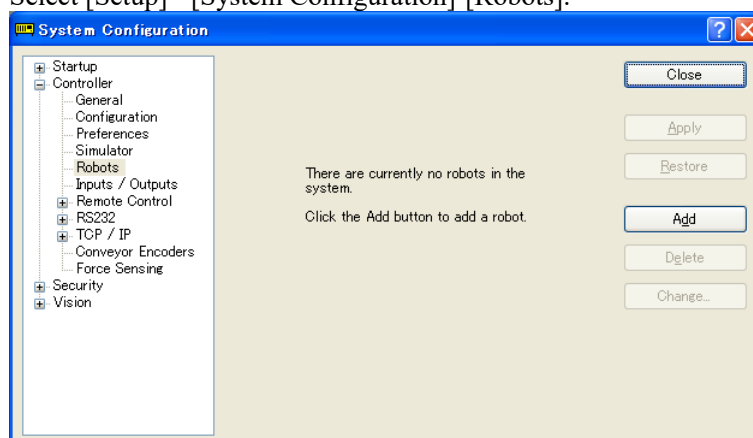

- (3) Click the **Add** button. The Add New Robot dialog will be displayed. Enter the name of the robot and serial number. Select **PG** motion system.

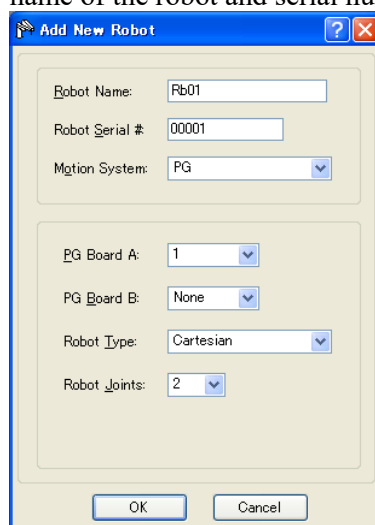

- (4) Select PG board A, Robot Type, and the number of joints used on the robot.  
For the Cartesian coordinate robot, select “Cartesian”.  
For the Joint type robot, select “Joint”.  
In case of the Joint type robot with more than 5 joints, select also “PG board B”.
- (5) Click the **OK** and reboot the controller.
- (6) After the controller is rebooted, a PG robot is added to EPSON RC+.

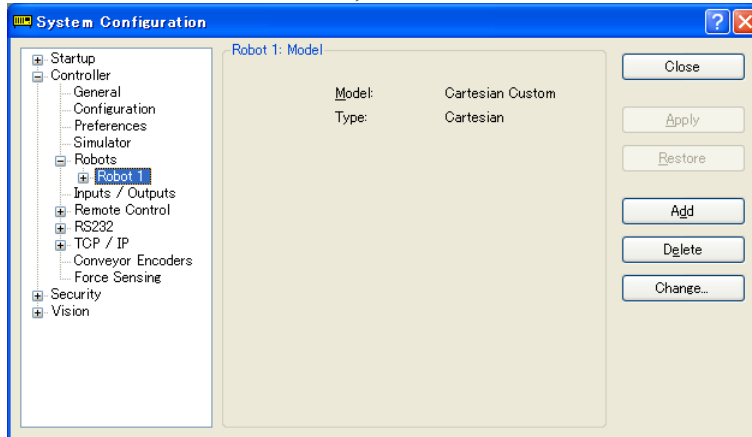



## 3.2 PG Robot Configuration

Once a PG robot has been added to the system, you must configure it for the PG Robot Configuration.

### 3.2.1 PG Robot Parameters Overview

To configure parameters for a PG robot:

- (1) Start EPSON RC+.
- (2) Select [Setup]-[System Configuration]-[Robot].
- (3) Select a PG parameter of the PG robot you want to edit the setting.

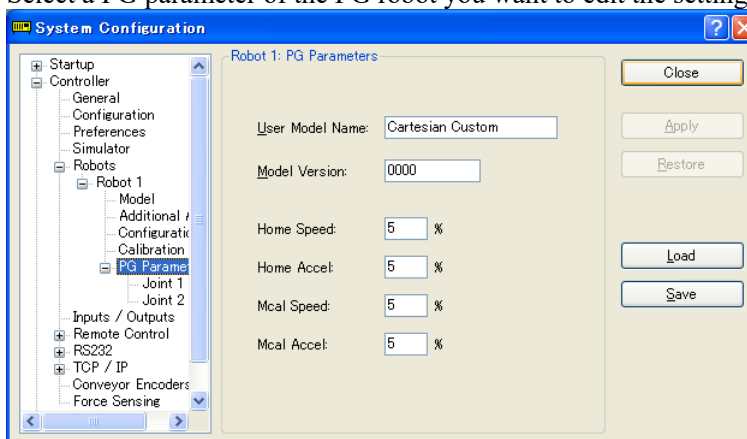

- (4) Follow the instruction in 3.2.3 *PG Parameter* and follows to change the parameter settings.

Click **Apply** to save the new settings.



CAUTION

- Set PG robot parameters with extra caution.

If parameters are set improperly, the robot may move unexpectedly. The unexpected movement of the robot is extremely hazardous and may cause damage to the robot and / or peripheral equipment.

### 3.2.2 PG Parameters

This dialog allows you to configure the parameters for the new robot. If you already have a data file from a previously created PG robot, click OK to accept default parameters, then use the Load Parameters button to load the data file.

If you have a PG robot data file previously created

Load the data file by following the instruction in the section *3.2.4 Backup and Restore Parameter Data*.

If you don't have a data file, then proceed to the following sections to configure the PG robot parameters.

If you don't have a data file

Set the PG robot parameter in the dialog shown below.

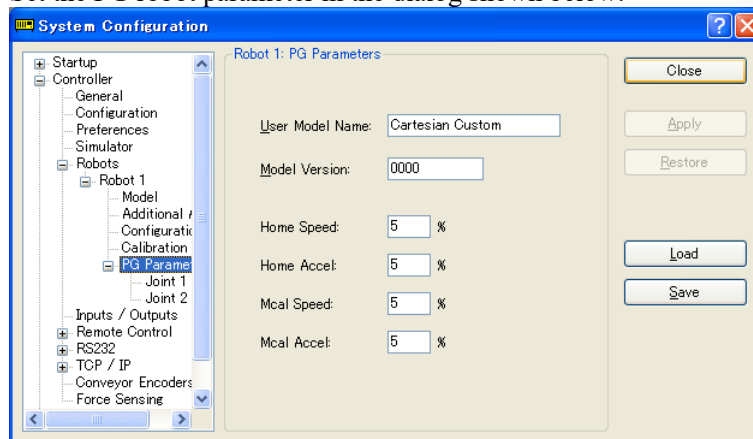

#### User Model Name

Name the model of the manipulator here. You may create your own type-name using a maximum of 32 alphanumeric characters.

The User Model Name entered here will appear as the robot type in Robot Configuration. The User Model Name does not affect robot operation.

#### Model Version

This indicates the data version in a 4-digit hexadecimal number. This information does not affect robot operation. The version number is for your own use to indicate different versions of robots using the same User Model Name.

#### Home Speed

This parameter sets the speed when **Home** is executed, specified by percentage of maximum speed. The value must be an integer in the range of 1 to 100.

#### Home Accel

This parameter sets the acceleration when HOME is executed, specified by percentage of maximum acceleration. The value must be an integer in the range of 1 to 100.

#### Mcal Speed

This parameter sets the speed when MCAL is executed, specified by percentage of maximum speed. The value must be an integer in the range of 1 to 100.

### Mcal Accel

This parameter sets the acceleration when MCAL is executed, specified by percentage of maximum acceleration. The value must be an integer in the range of 1 to 100.



Specify this parameter so that MCAL is completed within 120 seconds.

If the calibration of each joint is not completed within 120 seconds during MCAL execution, then error 4083: MCAL did not complete in time will occur.

### 3.2.3 PG parameter Joint

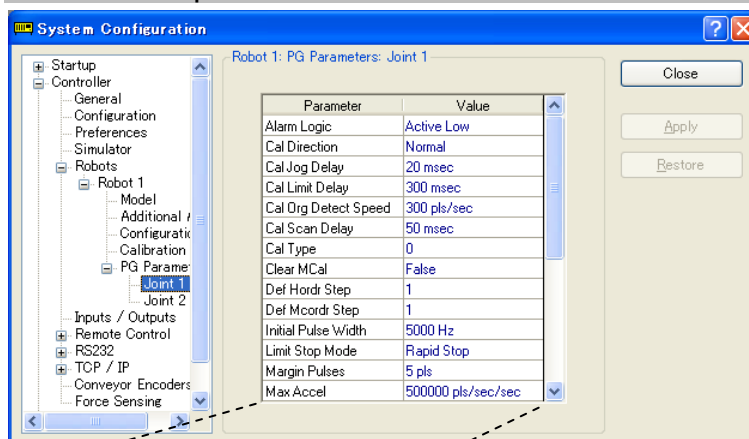

Parameter	Value
Alarm Logic	Active Low
Cal Direction	Normal
Cal Jog Delay	20 msec
Cal Limit Delay	300 msec
Cal Org Detect Speed	300 pls/sec
Cal Scan Delay	50 msec
Cal Type	0
Clear MCal	True
Continuous Motion	Disabled
Def Hordr Step	1
Def Mcoodr Step	1
Initial Pulse Width	5000 Hz
Limit Stop Mode	Rapid Stop
Margin Pulses	5 pls
Max Accel	500000 pls/sec/sec
Max Decel	500000 pls/sec/sec
Max Range	1000 pls
Max Speed	100000 pls/sec
Min Range	0 pls
Motor Type	Stepper
Origin Pulses	0 pls
Physical / Logical Pulses	Same
Pulse Output	CW/CCW
Reduction Ratio Joint	10 mm or deg
Reduction Ratio Pulses	1000 pls
Relative Motion	Disabled
SCurve	Disabled
Z Joint	False

### Alarm Logic

The ALM input logic is defined as follows when you select either Active High or Active Low from the drop-down list:

<b>Active High</b>	The alarm status is active when the input at the ALM input terminal is at High Active.
<b>Active Low</b>	The alarm status is active when the input at the ALM input terminal is at Low Active.

### Cal Direction

This setting defines the direction for the joint to move when calibrating the mechanical origin:

<b>Normal</b>	The joint moves in the normal direction during calibration of the mechanical origin.
<b>Reverse</b>	The joint moves in the reverse direction during calibration of the mechanical origin.

### Cal Jog Delay

The Jog Delay sets the delay (in msec) per pulse for the low speed, pulse-by-pulse operation during signal detection.

The value must be an integer in the range of 0 to 1275 and a multiple of 5 (msec).

### Cal Limit Delay

The Limit Delay sets the time duration (in msec) before reverse motion starts after either the CCW or CW Limit is detected during calibration.

The value must be an integer in the range of 0 to 1275 and a multiple of 5 (msec).

### Cal Org Detect Speed

This is the speed for detecting the sensor edge in pulses/sec.

The value must be an integer in the range of 1 to 65535.

### Cal Scan Delay

The Scan Delay sets the time duration (in msec) before reverse motion starts after the stop command is input during calibration.

The value must be an integer in the range of 0 to 1275 and a multiple of 5 (msec).

### Cal Type ORG

The Calibration Type specifies the calibration method used to calibrate the mechanical origin. There are seven calibration types 0, 1, 2, 3, 4, 5 and 10. For details of each type, refer to 4. *Calibration Types*.

### Clear MCAL

The check on this box clears the existing MCAL records when either MOTOR OFF or SFREE is executed. Execution of either MOTOR OFF or SFREE necessitates execution of MCAL after the motor is let go of servo by either of these commands.

<b>False</b>	The MCAL records will not be cleared when either MOTOR OFF or SFREE is executed. If it is a stepping motor that is driving the joint, this box must be left unchecked.
<b>True</b>	The MCAL records will be cleared when either MOTOR OFF or SFREE is executed. Execution of either MOTOR OFF or SFREE necessitates execution of MCAL after the motor is let go of servo by either of those commands. If it is a servo motor connected to the SVON output that is driving the joint, this box must be checked.

### Continuous Motion

Enables the continuous rotation in the any direction. This is used in the rotary table or other controls. This is for only the Joint type robots.

<b>Disabled</b>	Continuous operation is not enabled (Default)
<b>Abled</b>	Continuous operation is enabled If the continuous operation is enabled, normal absolute position management is not executed. In addition, only the motion commands for the continuous rotation (PG_Scan, PG_SlowStop, PG_FastStop) are enabled and the manipulator will not move with other motion commands. PG_Scan 0 : Continuous motion in CW direction.

### Default Horder

When **Home** (a command to move to the user-defined home position) is executed, each joint will be moved to the -defined home position in the order as specified by the **Horder** command.

When the user clicks **Default** button in the Tool | Robot manager | Home Config, these values will be used.

For the details, refer to 3.3.3 [*Home Config*].

### Default MCORDR

When MCAL (calibration to the home position) is executed, each joint will be calibrated to the mechanical home position in the order as specified by the MCORDR command.

When you click **Default** button in the Tool | Robot manager | Mcal Order, these values will be used.

For the details, refer to 3.3.4 [*Mcal Order*].

### Initial Pulse Width

Use this parameter to control the initial pulse width to prevent power swing at the stepper motor. The value in the range of 1 to 8388607.

### Limit Stop Mode

This specifies how the robot will be stopped when a limit signal is turned OFF. Select from the drop-down list box either **Rapid Stop** (stop immediately) or **Decel Stop** (gradually decelerate to stop).

### Margin Pulses

During the calibration without the acceleration or deceleration, when the calibration signal is detected, the arm stops after moving for the part of margin pulses in the traveling direction. This is used to prevent the false detection by the origin signal chattering or hunting. The value must be an integer in the range of 1 to 65535.

### Max Accel, Max Decel Max, Speed

These correspond with the SPEL+ commands SPEED 100, and ACCEL 100, 100, whose values are percentages.

<b>maximum speed</b> [pulse/sec]	Real value from 0.1 to 6553400.0
<b>maximum acceleration</b> [pulse/sec <sup>2</sup> ]	Real value from 200.0 to 400000000.0
<b>maximum deceleration</b> [pulse/sec <sup>2</sup> ]	

### Max Range, Min Range

This is the default working range for the robot. The value must be a signed integer in the range of -2147483648 to 2147483647.

When the user clicks **Default** button in the Tool | Robot manager | Range, these values will be used.

For the details, refer to 3.3.2 [Range].

### Motor Type

Specifies the target motor type. Select either **Servo** or **Stepper**.

If **Servo** is selected, the following signals will become effective: Positioning Output of the servo drive (DEND), Counter Reset Input (DRST) and Servo ON (SVON).

### Origin Pulses

Specifies the pulse position after the calibration. The specified pulse value is the position at where the arm is after the calibration with MCal. The value must be a positive / negative integer.

### Physical / Logical Pulses

Set the relation of the direction of the motor rotation and the pulse values (coordinate values) in SPEL+. Select Same or Reverse from the drop-down list.

<b>Same</b>	As physical encoder values increase, SPEL+ pulse values increase.
<b>Reverse</b>	As physical encoder values increase, SPEL+ pulse values decrease.

### Pulse Output

Select the pulse output type from the drop-down list to match to the motor drive's specification:

<b>Pulse / Direction</b>	For this setting, the pulse signal is generated from the CWP output while the Direction signal will be generated from the CCWP output. The direction will be + (CW) when CCWP is low, and - (CCW) when CCWP is high.
<b>CW / CCW</b>	For this setting, the pulse in + (CW) direction is generated from the CWP terminal while the pulse in - (CCW) direction will be generated from the CCWP terminal.

### Reduction Ratio Joint, Reduction Ratio Pulses

This defines the number of pulses that correspond with the travel distance in millimeters or degrees.

This sets the pulse number to the reduction ratio pulse, travel distance (angle) to the reduction ratio joint.

Input range is an integer from 1.0 ~ 1000000.0.

### Relative Motion

This enables the relative rotary motion in any directions. This is used to control such as the rotary index. This is for only the Joint type robots.

<b>Disabled</b>	Relative motion is not enabled (Default)
<b>Abled</b>	Relative motion is enabled When the relative motion is enabled, normal absolute position management is not executed. The point data for the motion command is considered as the relative travel amount from the current position. <code>Go XY(100, 0, 0, 0) ` Moves 100 mm or 100 degrees from the current position.</code>

### SCurve

This sets the acceleration speed curve to Straight or S-curve Acceleration/Deceleration.

<b>Disabled</b>	Straight Acceleration/Deceleration (Default)
<b>Abled</b>	S-curve Acceleration/Deceleration In the S-curve Acceleration/Deceleration, it creates an acceleration/deceleration curve which changes the speed smoothly. Also, it can prevent the triangle drive in small distance motions.

### Z Joint

Specify the joint designated as Z-joint (vertical operation joint) when the JUMP command is executed in SPEL+. For Cartesian robots, the Z joint is fixed at joint #3.

### 3.2.4 Backup and Restore Parameter Data

After creating a PG robot, you can save its parameter data in a file. This file can be used as a backup, and can also be used to create PG robots on other systems.

To backup PG robot parameter data:

- (1) Select System Configuration from the Setup menu.
- (2) Select the Robot from the System Configuration.
- (3) Select the desired PG robot from the list of Robot, and then select a PG parameter.
- (4) Click the <Save>button.

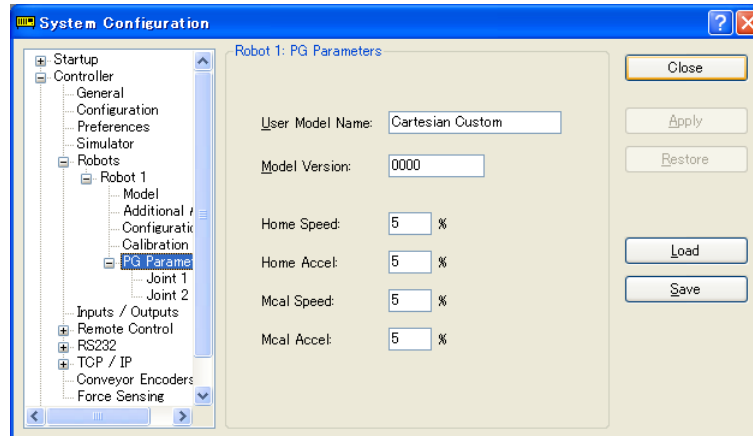

- (5) Browse to the desired location and enter the desired filename.

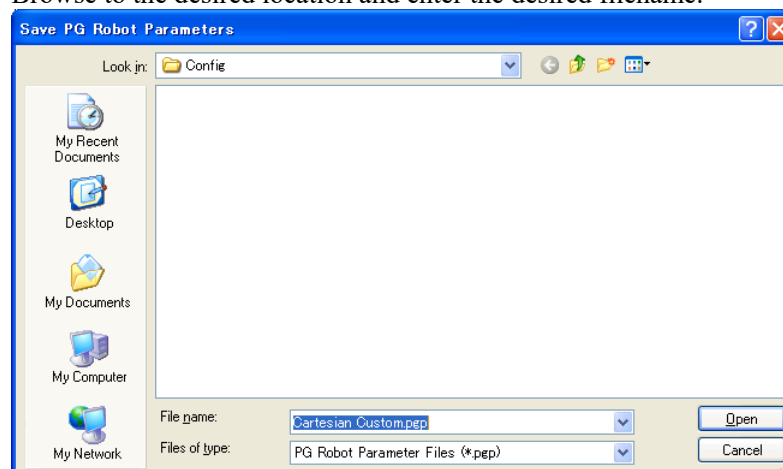

- (6) Click the <Save>button.



To restore PG robot parameter data:

- (1) Select System Configuration from the Setup menu.
- (2) Select the Robot from the System Configuration
- (3) Select the desired PG robot from the list of Robot, and then select a PG parameter.
- (4) Click the <Load>button.

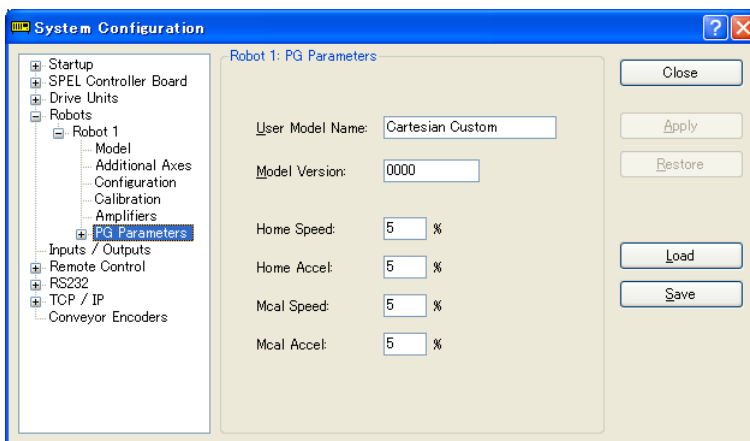

- (5) Browse to the desired location and select the desired filename.

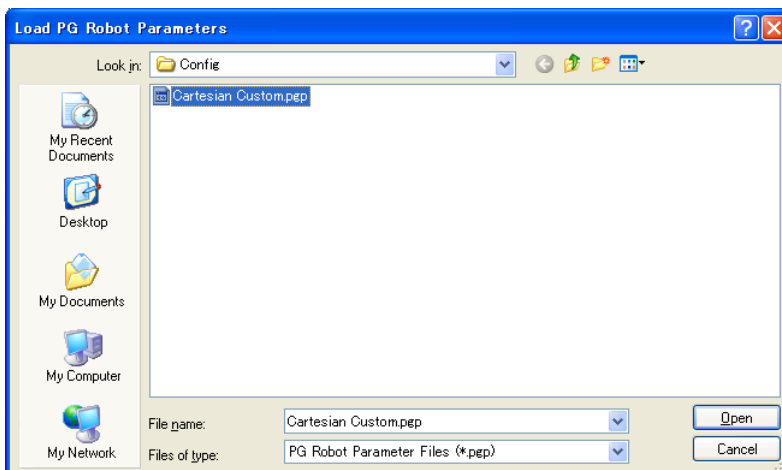

- (6) Click the <Open> button. The parameters are now loaded.

## 3.3 [Robot Manager] Configuration

After the PG robot parameter configuration is completed, now you need to set the parameters in the [Robot Manager].

### 3.3.1 Overview of [Robot Manager]

This is used to control the robot motors and power, jog robots, teach points, and view/edit several parameters for the robot.

For the details, refer to *EPSON RC+ Users Guide: 5.11.1 [Robot Manager Command] (Tools Menu)*.

This section describes an instruction for the PG robot parameter setting.

#### How to edit the [Robot Manager]

- (1) Start the EPSON RC+.
- (2) Select the Robot Manager from the Tools menu.

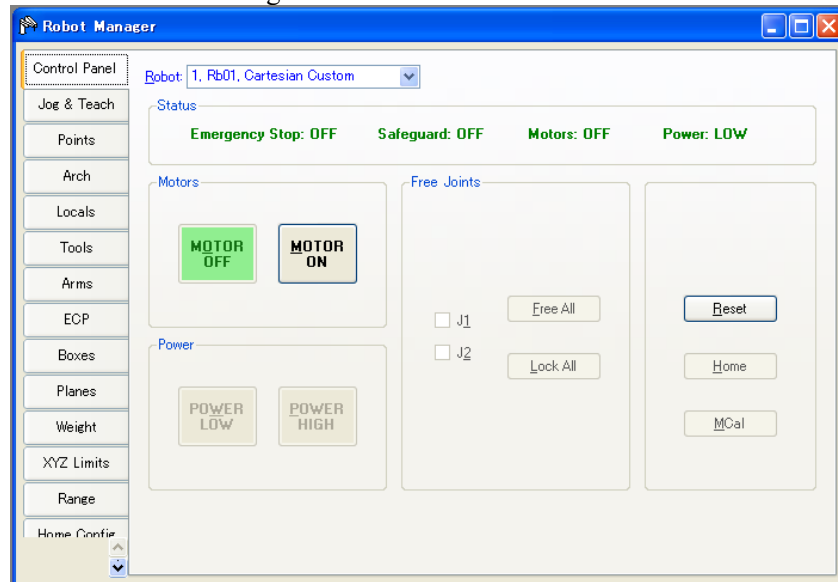

- (3) Follow the instruction in the section 3.3.2 [Range] or later to change the parameters.
- (4) Click the <Apply> button and save the new settings.

## 3.3.2 [Range]

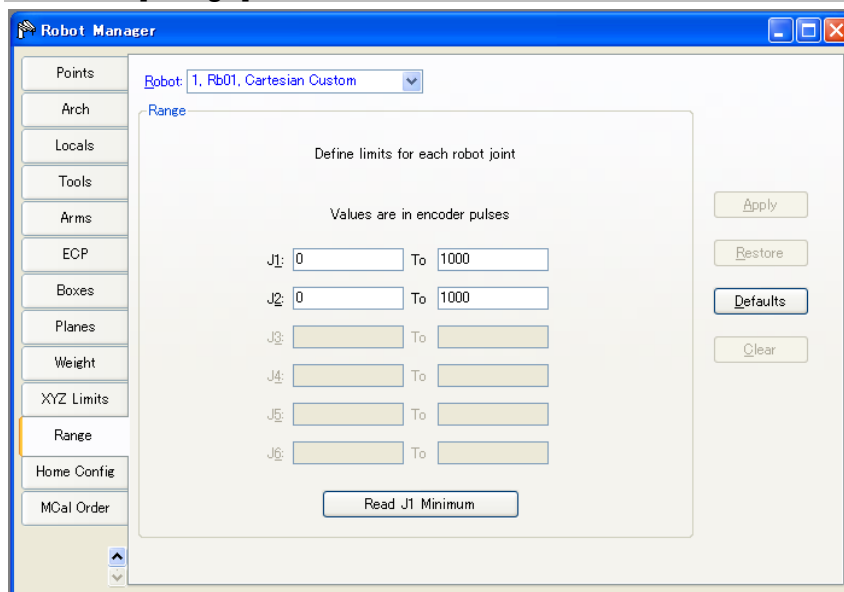

Set the robot motion range. Click the <Default> button if you want to load the default values set in the section 3.2.3 *PG parameter Joint*.

For each Joint (J1 through J4), specify the minimum value in the box on your left and the maximum on the right. The value must be a signed integer in the range of  $-2147483647$  to  $2147483647$ .

## 3.3.3 [Home Config]

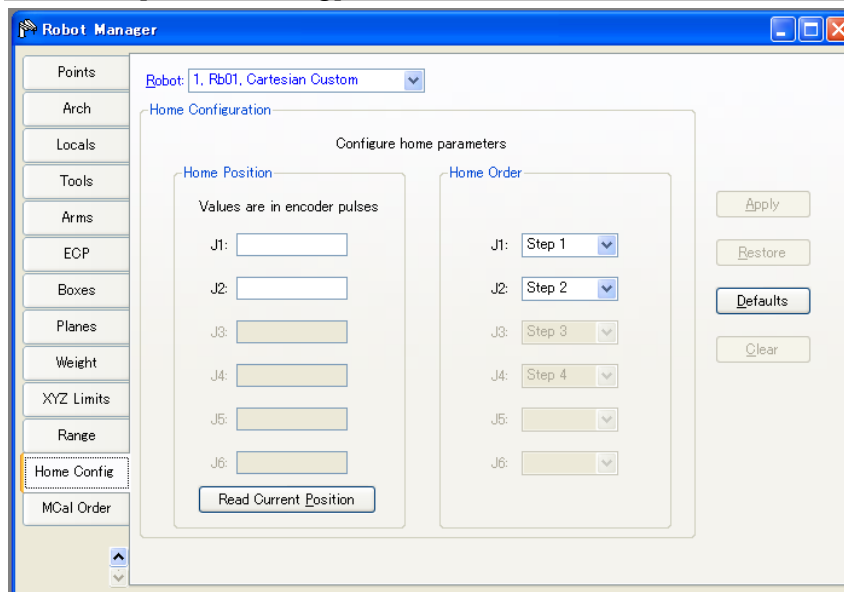

When HOME (a command to move to the user-defined home position) is executed, each joint will be moved to the user-defined home position in the order as specified by the HORDR command.

Click the <Default> button if you want to load the default values set in the section 3.2.3 *PG parameter Joint*.

J1 through J6 represent Joint #1 through Joint #6 respectively and, they are moved to the user-defined home position in the order as specified by Step 1 through Step 4. In the illustrated example, the Joint #2 will be moved to the user-defined home position after Joint #1 is calibrated and moved to the waiting position.

### 3.3.4 [Mcal Order]

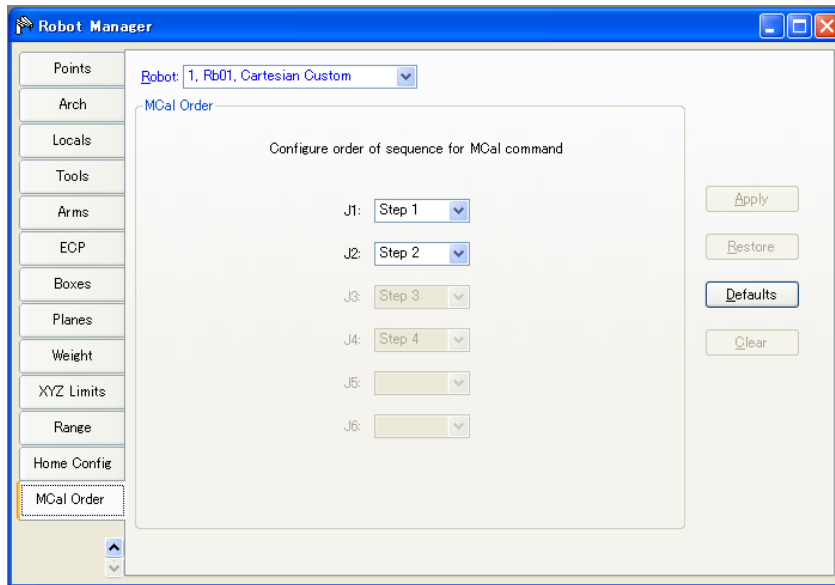

Specify this parameter so that MCAL is completed within 120 seconds.



If the calibration of each joint is not completed within 120 seconds during MCAL execution, then error 4083, MCAL did not complete in time, will occur.

When MCAL (calibration to the home position) is executed, each joint will be calibrated to the mechanical home position in the order as specified by the MCORDER command. The values to be entered here specify the default values for MCORDER.

Click the <Default> button if you want to load the default values set in the section 3.2.3 *PG parameter Joint*.

J1 through J6 represent Joint #1 through Joint #6 respectively and they will be calibrated in the order as specified by Step 1 through Step 4. In the illustrated example, the Joint #2 will be calibrated to the origin position after Joint #1 is calibrated and moved to the origin position.

## 3.4 Using PG Robots in EPSON RC+

PG robots behave similar to standard robots. You use Robot Control Panel, Jog & Teach, Point Editor, etc. the same as you would with standard robots.

Refer to the EPSON RC+ User's Guide for details on using the GUI and program development.

The following sections contain additional information that is specific to PG robots.

### 3.4.1 PG Cartesian Robots

PG Cartesian robots can be from 1 to 4 joints. The joint names are shown in the table below.

Joint #	Joint Name
1	X
2	Y
3	Z
4	U

Joint #3, if used, is fixed as the Z joint. You cannot set which joint is the Z joint for a PG Cartesian robot.

Vision Guide supports Cartesian robots with 2 or more joints.

PG Cartesian robots support Arm, Tool, and Local.

### 3.4.2 PG Joint Robots

PG Joint robots do not have an XY coordinate system.

Vision Guide does not support Joint robots (since there is no XY coordinate system).

PG Joint robots do not support Arm, Tool, and Local.

The table below shows the functions used to retrieve coordinates for joint robots. Normally, for Joint robots, use Agl and PAgl functions. However, you can also use the CX, CY, CZ, CU functions, as shown.

	Joint						
	J1	J2	J3	J4	J5	J6	J7
Current Position	Agl(1) CX(Here)	Agl(2) CY(Here)	Agl(3) CZ(Here)	Agl(4) CU(Here)	Agl(5) CV(Here)	Agl(6) CW(Here)	Agl(7) CR(Here)
Point coordinate	PAgl(Pn, 1) CX(Pn)	PAgl(Pn, 2) CY(Pn)	PAgl(Pn, 3) CZ(Pn)	PAgl(Pn, 4) CU(Pn)	PAgl(Pn, 5) CV(Pn)	PAgl(Pn, 6) CW(Pn)	PAgl(Pn, 7) CR(Pn)

### 3.4.3 Tuning

Tuning for PG robot drives is handled by the third party motor drive. Refer to the drive manufacturer's instructions on how to tune the drive. EPSON RC+ does not provide any commands for tuning the drive. However, if the drive can be controlled from a DLL, it is possible to execute DLL functions from a SPEL+ program.

### 3.4.4 Motion Commands

PTP (point to point) motion commands are supported for PG robots. These include Go, TGo (Cartesian only), and Jump.

Joint motion is not synchronized for PG robots. When a motion command using more than one joint is executed, the joints do not complete their motion at the same time.

CP motion (linear interpolated) commands are not supported. These include Move, TMove, Arc, and Curve.

The Jump motion command is supported for PG robots that have a Z joint.

PASS operation with CP ON is not continuous. A PASS operation cannot be continued to the next operation as one smooth continuous motion in which an action to the first PASS operation/command slows down to move into another action in accelerating motion. Attempting a PASS operation via CP ON command will only operate the manipulator by one motion at a time.

### 3.4.5 SLock and SFree

Connecting the servo drive to the SVON signal enables servo excitation control via the SLock and SFree commands. However, MCal must be executed before servos can be set to free. (This is because the manipulator is possibly out of position while at servo-free.) In order to ensure MCal execution, set as follows in the software: Enable the [Clear MCal] in the Configuration dialog | System the Robot.

When you execute a manipulator motion command without executing MCal command, error message “Error 4014: MCAL has not completed.” is displayed.

The stepper motor itself is not capable of controlling excitation, and normally, the SVON output signal cannot be used. However, by executing SFree, the manipulator can be operated in a pseudo servo-free state when the motor is actually engaged. When you execute SFree, make sure to execute SLock in order to restore the excitation state.

### 3.4.6 Dry Run

PG robots are not directly supported in Dry Run. For PG robots to be used, the PG board hardware must exist on the system. If you enable Dry Run in EPSON RC+, the PG robots will continue to operate from the hardware.

### 3.4.7 PG Signal Status Display

Input and output status of the PG board can be displayed on the EPSON RC+ GUI.

When the PG robot is selected, open the [I/O Monitor] of the EPSON RC and select [PG Status] tab.

The [PG Status] tab cannot be displayed in the [I/O Monitor] in the Operator mode.

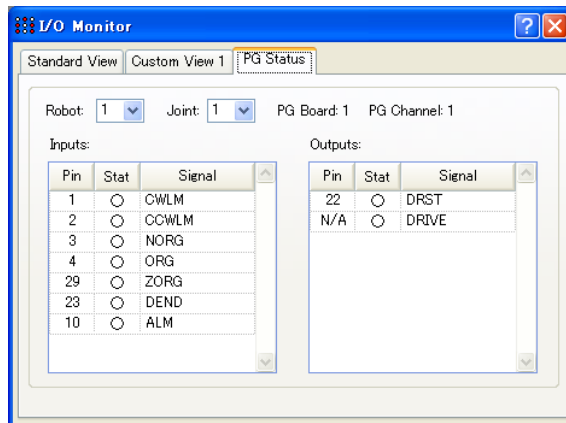

DRIVE signal turns “On” while the pulse waveform is output. It does not represent the status of the pulse waveform itself.

## 4. Calibration Types

The table below lists the seven Calibration Types. These calibration types determine how the mechanical origin is determined during MCal.

Cal Type	Number of sensors	Sensor Status when calibration is complete	Standard Number of Steps	Accuracy* <sup>1</sup>	Calibration Time* <sup>2</sup>
0	1	OFF	2	C	Shorter
1	1	ON	2	C	Shorter
2	1	OFF	4	B	Longer
3	1	ON	4	B	Longer
4	2	OFF	4 or 5	A	Longest
5	2	ON	4 or 5	A	Longest
10	2	ON	2	C	Shortest



\*1: A is highest accuracy followed by B and then C.

\*2: Complete the calibration of each joint within 120 seconds.





### Calibration Sequence per Calibration Type

The following conventions and symbols are used in the Calibration Sequence diagram in the following pages:

● or ○	The starting position of the search for the mechanical origin.
↓	Pause
▼	The position for the calibration to complete. (A target origin)
	The accelerating or decelerating motion in the direction of arrow while detecting signals. (Dotted Line indicates a motion to return to the origin from outside the Permissible Working Range.)
	The motion without acceleration or deceleration in the direction of arrow while detecting signals.
	The motion in the slow speed pulse by pulse in the direction of arrow while detecting signals.

The arrow indicates the two types of operation speed as follows:

	Run at the speed as specified in the MCAL tab of the PG Robot Configuration dialog.
	Run at the speed as specified in the Origin Edge Detect Speed in the Calibration tab of the PG Robot Configuration dialog.

The following symbols marked next to ↓ (Pause) in the illustration indicates the duration of time to pause as follows:

LD	Pause for delay time as specified in <b>Limit Delay</b> on Calibration tab of the PG Robot Configuration dialog.
SD	Pause for delay time as specified in <b>Scan Delay</b> on Calibration tab of the PG Robot Configuration dialog.
JD	Pause for delay time as specified in <b>Jog Delay</b> on Calibration tab of the PG Robot Configuration dialog.

#### 4. Calibration Types

---

Whichever Calibration Type is specified, wiring must be done in such a way to prevent chattering. Also, the following signal conditions must be satisfied:

Cal Type 0  $\overline{\text{ORG}}$  pulse width : 1 msec or over

Cal Type 1  $\overline{\text{ORG}}$  pulse width : 1 msec or over

Cal Type 2  $\overline{\text{ORG}}$  pulse width : 1 msec or over

Cal Type 3  $\overline{\text{ORG}}$  pulse width : 1 msec or over

Cal Type 4  $\overline{\text{NORG}}$  pulse width : 1 msec or over

The interval between the  $\overline{\text{NORG}}$  signal edge and  $\overline{\text{ORG}}$  signal edge:  
5 msec or over

+ZORG/-ZORG pulse width : 10  $\mu$ sec or over (when a servo motor is used.)

Cal Type 5  $\overline{\text{NORG}}$  pulse width : 1 msec or over

The interval between the  $\overline{\text{NORG}}$  signal edge and  $\overline{\text{ORG}}$  signal edge:  
5 msec or over

+ZORG/-ZORG pulse width : 10  $\mu$ sec or over (when a servo motor is used)

Cal Type 10  $\overline{\text{NORG}}$  Signal width : 1 msec or over

The interval between the  $\overline{\text{NORG}}$  signal edge and  $\overline{\text{ORG}}$  signal edge must be sufficient to enable the robot to stop by deceleration.

### Calibration Type 0

For Calibration Type 0, calibration is accomplished using one sensor. Place the sensor closer to the CCW Limit position. Configure the sensor to detect the ORG signal edge (↑) in the CW direction.

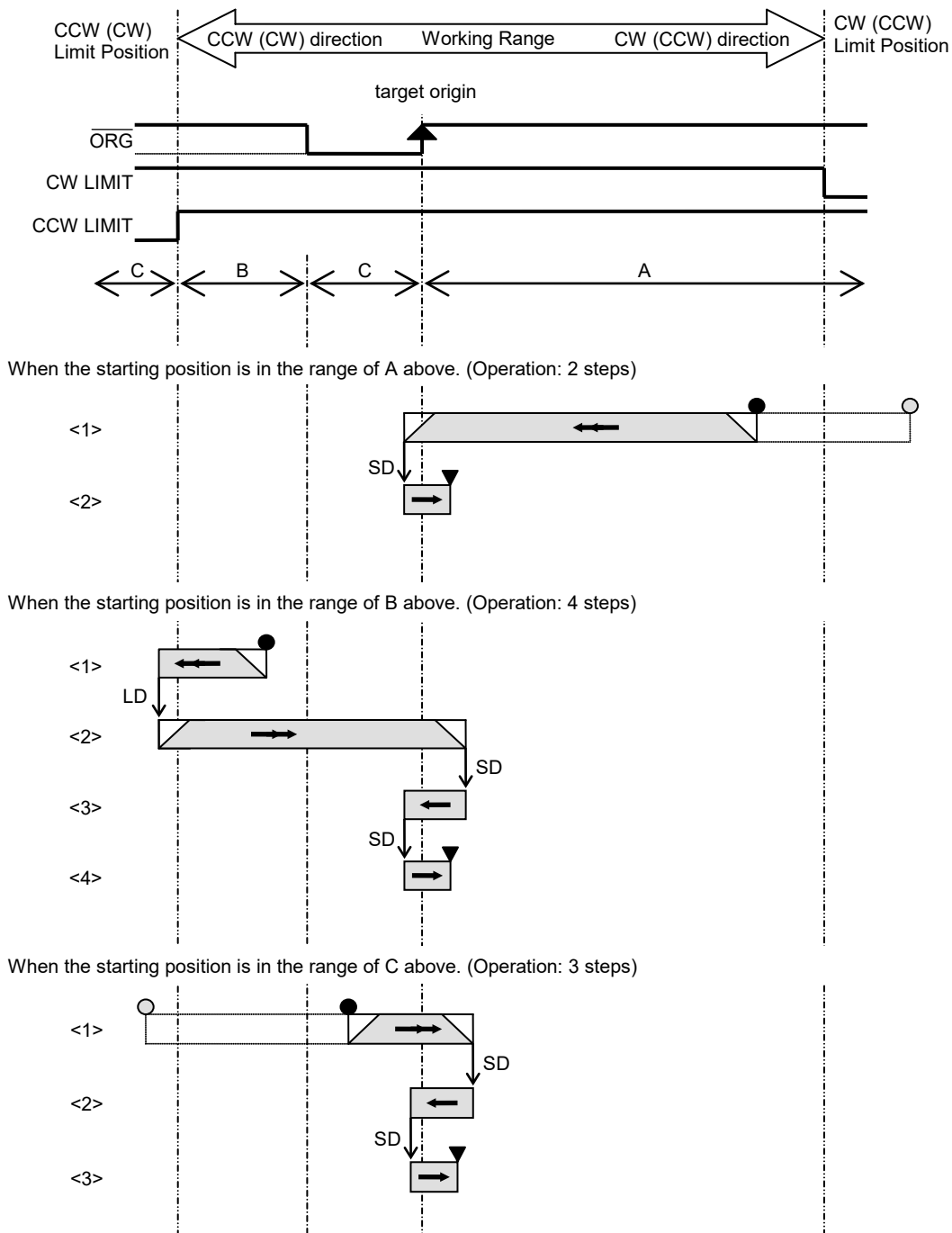

The above motion direction is subject to and affected by the **Direction** parameter in the System Configuration | Robot. The directions shown above without parentheses indicate the motion direction when Normal is selected while those marked in parentheses indicate the motion direction when Reverse is selected.

### Calibration Type 1

For Calibration Type 1, calibration is accomplished using one sensor. Place the sensor closer to the CCW Limit position. Configure the sensor to detect the ORG signal edge ( $\downarrow$ ) in the CCW direction.

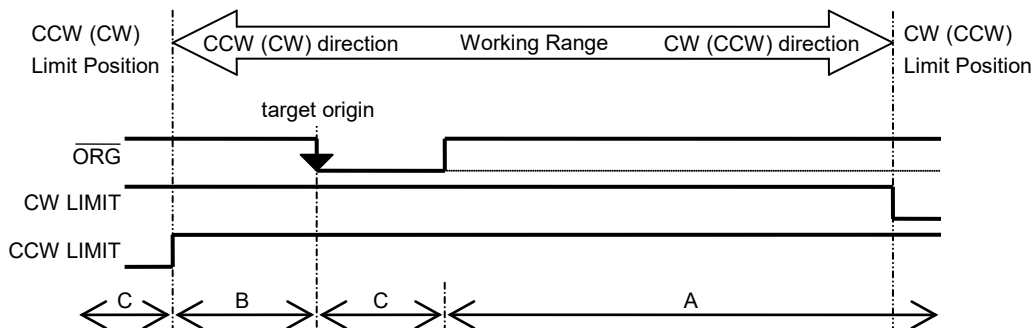

When the starting position is in the range of A above. (Operation: 2 steps)

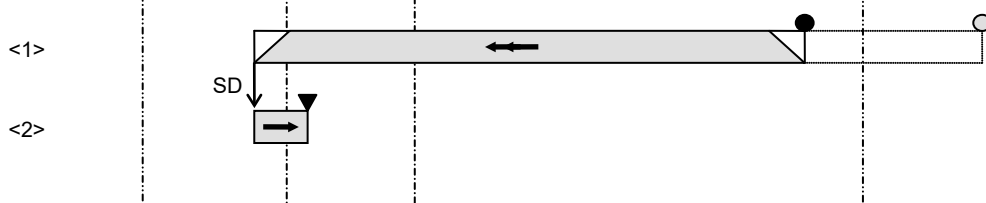

When the starting position is in the range of B above. (Operation: 4 steps)

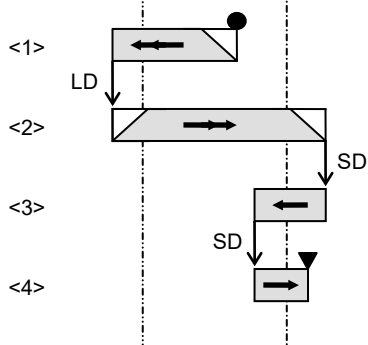

When the starting position is in the range of C above. (Operation: 3 steps)

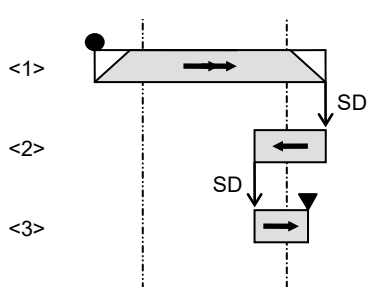

The above motion direction is subject to and affected by the Direction parameter in the System Configuration | Robot. The directions shown above without parentheses indicate the motion direction when Normal is selected while those marked in parentheses indicate the motion direction when Reverse is selected.

### Calibration Type 2

For Calibration Type 2, calibration is accomplished using one sensor. Place the sensor closer to the CCW Limit position. Configure the sensor to detect the ORG signal edge (↑) in the CW direction.

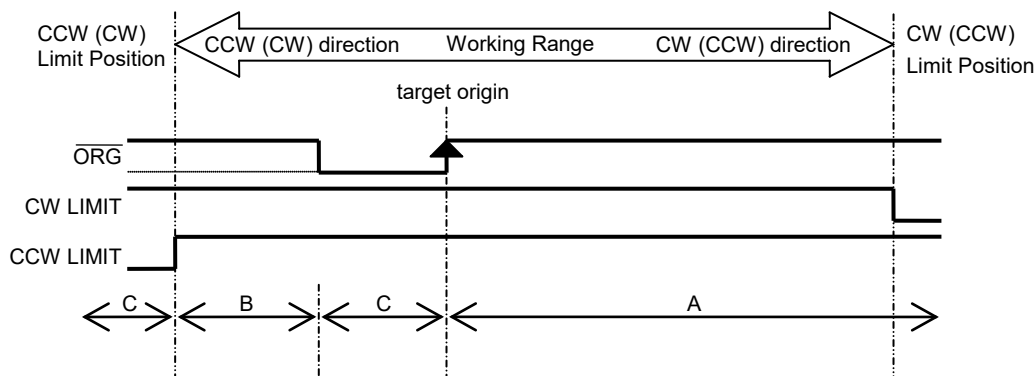

When the starting position is in the range of A above. (Operation: 4 steps)

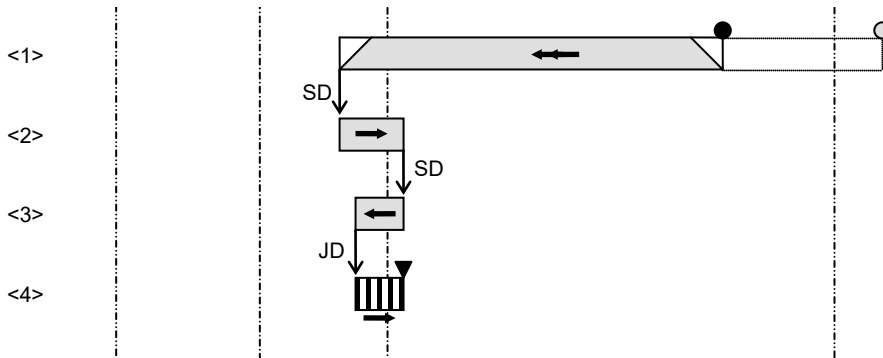

When the starting position is in the range of B above. (Operation: 4 steps)

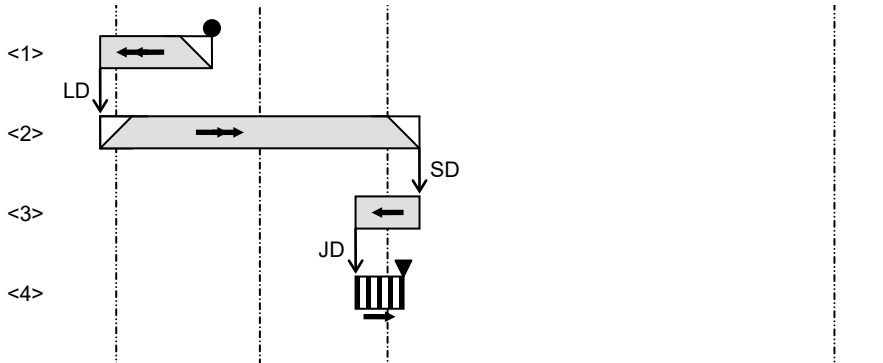

When the starting position is in the range of C above. (Operation: 3 steps)

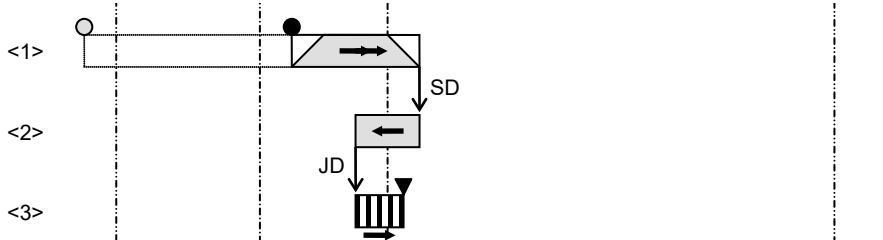

**NOTE**

The above motion direction is subject to and affected by the Direction parameter in the System Configuration | Robot. The directions shown above without parentheses indicate the motion direction when Normal is selected while those marked in parentheses indicate the motion direction when Reverse is selected.

### Calibration Type 3

For Calibration Type 3, calibration is accomplished using one sensor. Place the sensor closer to the CCW Limit position. Configure the sensor to detect the ORG signal edge ( $\downarrow$ ) in the CCW direction.

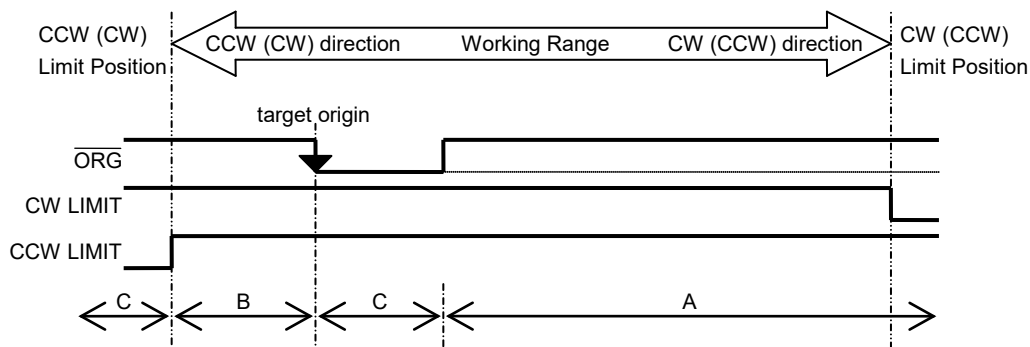

When the starting position is in the range of A above. (Operation: 4 steps)

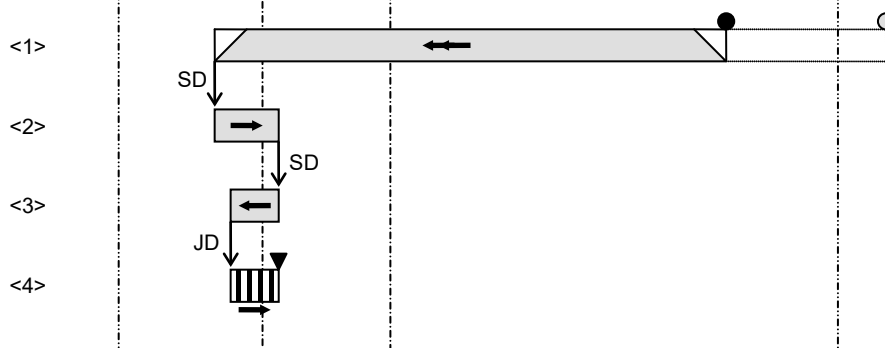

When the starting position is in the range of B above. (Operation: 4 steps)

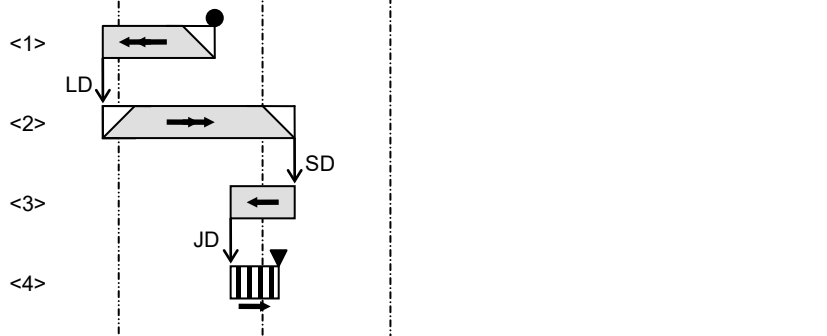

When the starting position is in the range of C above. (Operation: 3 steps)

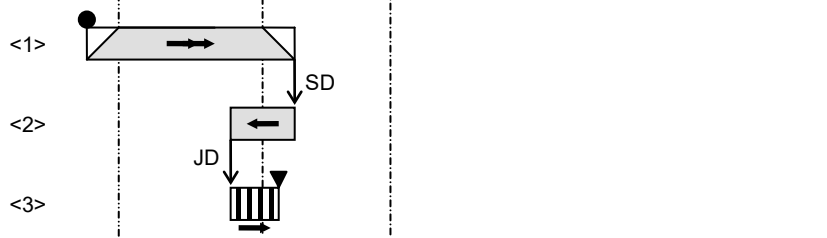

The above motion direction is subject to and affected by the Direction parameter in the System Configuration | Robot. The directions shown above without parentheses indicate the motion direction when Normal is selected while those marked in parentheses indicate the motion direction when Reverse is selected.

### Calibration Type 4

In Calibration Type 4, calibration is accomplished using two sensors. Use the NORG signal for rough positioning first. Then, to position more closely, pick up the ORG signal (if a stepper motor is used) or ZORG signal (if a servo motor is used). Place the NORG sensor in the direction of CCW Limit Position. Place the ORG sensor on the motor's rotation axis and, leave +ZORG disconnected when a stepper motor is used. When a servo motor is used, connect the +Z Phase of the servo motor to +ZORG and -Z Phase to -ZORG respectively. Leave ORG disconnected when a servo motor is used. The sequence of rough positioning in Calibration Type 4 using NORG signal is as follows:

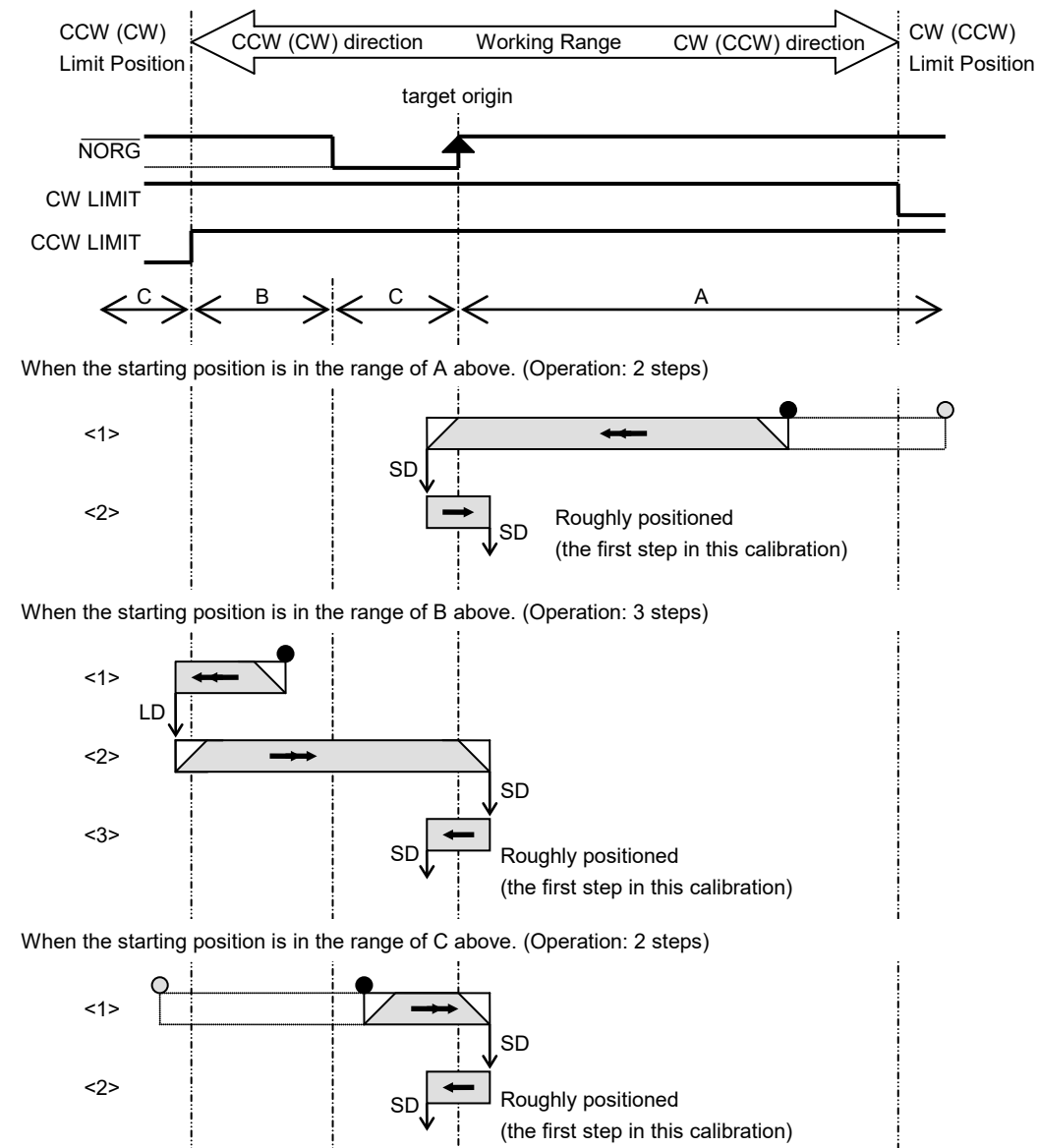

The above motion direction is subject to and affected by the Direction parameter in the System Configuration | Robot. The directions shown above without parentheses indicate the motion direction when Normal is selected while those marked in parentheses indicate the motion direction when Reverse is selected.

#### 4. Calibration Types

If a stepper motor is used, the following sequence follows according to the ORG signal status when the NORG (↑) is detected:

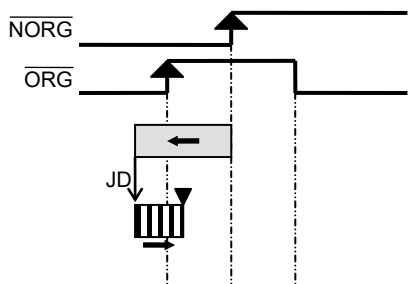

$\overline{\text{ORG}} = \text{HIGH}$  (sensor: OFF)  
when the  $\overline{\text{NORG}}$  (↑) is detected.

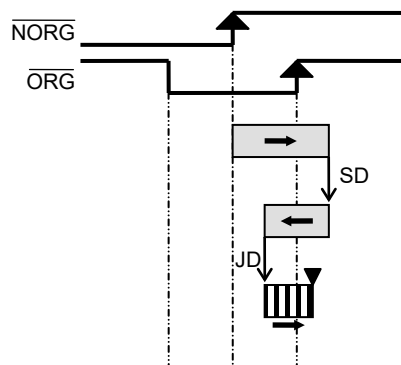

$\overline{\text{ORG}} = \text{LOW}$  (sensor: ON)  
when the  $\overline{\text{NORG}}$  (↑) is detected.



### Calibration Type 5

For Calibration Type 5, calibration is accomplished using two sensors. Use the NORG signal for rough positioning first. Then, to position more closely, pick up the ORG signal (if a stepper motor is used) or ZORG signal (if a servo motor is used). Place the NORG sensor in the direction of CCW Limit Position. Place the ORG sensor on the motor's rotation axis and, leave +ZORG unconnected when the stepper motor is used. When a servo motor is used, connect the +Z Phase of the servo motor to +ZORG and the -Z Phase to -ZORG. Leave ORG disconnected when a servo motor is used. The sequence of rough positioning for Calibration Type 5 using NORG signal is as follows:

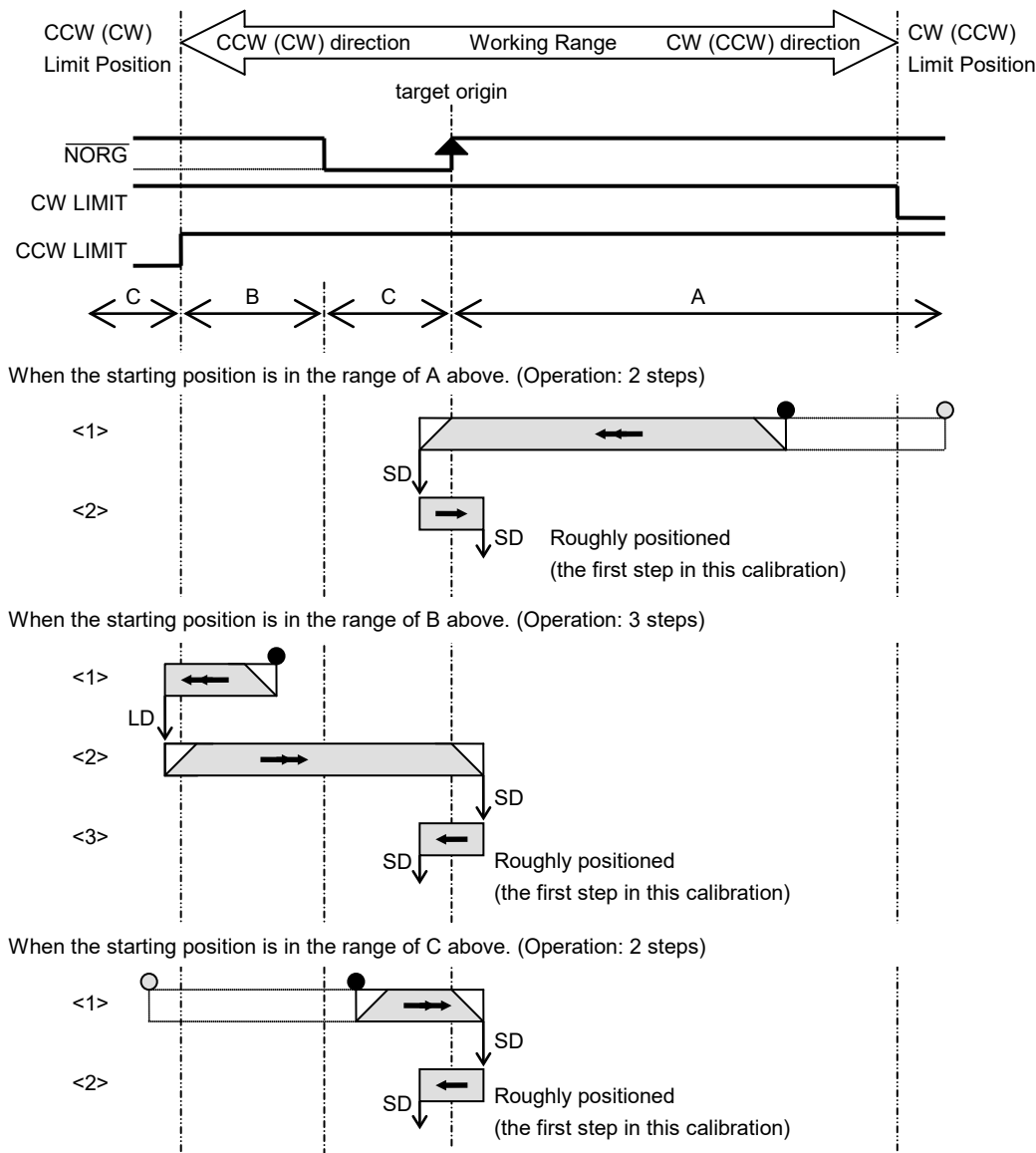

The above motion direction is subject to and affected by the Direction parameter in the System Configuration | Robot. The directions shown above without parentheses indicate the motion direction when Normal is selected while those marked in parentheses indicate the motion direction when Reverse is selected.

#### 4. Calibration Types

If a stepper motor is used, the following sequence occurs according to the ORG signal status when the NORG ( $\uparrow$ ) is detected:

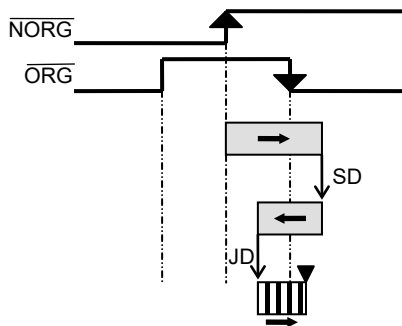

$\overline{\text{ORG}} = \text{HIGH}$  (sensor: OFF)  
when the  $\overline{\text{NORG}} (\uparrow)$  is detected.

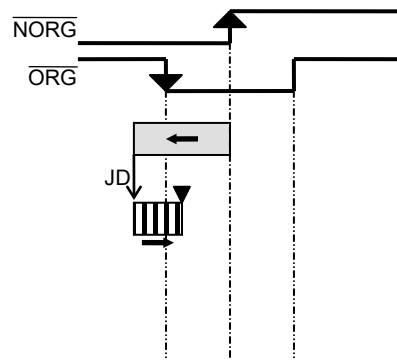

$\overline{\text{ORG}} = \text{LOW}$  (sensor: ON)  
when the  $\overline{\text{NORG}} (\uparrow)$  is detected.

### Calibration Type 10

In ORG Type 10, calibration is accomplished using two sensors. Detect either the NORG or ORG signal edge in the CW direction. In the end, detect ORG signal edge (↓) in the CW direction. Keep both the NORG and ORG signals either one pulse or at the same level as CCW:

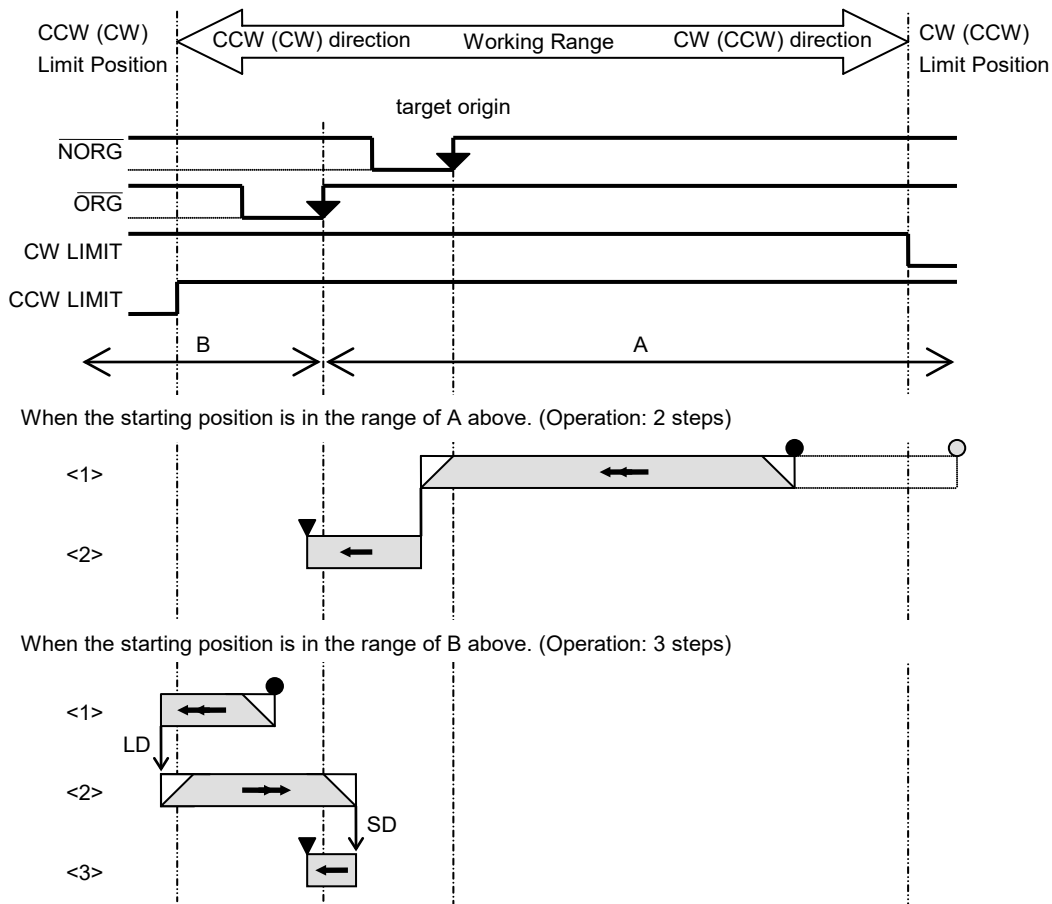

The above motion direction is subject to and affected by the Direction parameter in the System Configuration | Robot. The directions shown above without parentheses indicate the motion direction when Normal is selected while those marked in parentheses indicate the motion direction when Reverse is selected.

## 5. Troubleshooting

This chapter describes how to deal with common problems that can occur when using the PG motion system.

Most of the errors that occur when a PG board is installed in your system for the first time are likely due to any of the following: wrong wiring, wrong parameter or the servo drive settings. When a trouble happens, read this and the drive's manual carefully.

<b>Robot operating speed does not increase</b>	
Cause	Solution
The SPEL+ Power setting is set to Low.	Set Power to High.
There are invalid parameter settings.	Refer to the section 3.3 [ <i>Robot Manager</i> ] <i>Configuration</i> and ensure that there are no invalid settings.

<b>Motor oscillates</b>	
Cause	Solution
Wiring for the Motor Power signal or the Encoder signal is incorrect between the drive and motor.	Check the wiring and correct if necessary.
The gain setting on the drive is not appropriate for the load.	Reset the gain properly by referring to the drive's manual.

<b>Motor does not run</b>	
<b>Cause</b>	<b>Solution</b>
The safeguard input signal is not connected properly or the safeguard is open.	When the safeguard is open, the robot can only be operated by a teaching device. Assure that the safeguard input is wired properly and operate with the safeguard closed. Refer to the Robot Controller manual and the EPSON RC+ User's Guide for more details.
The pulse output signal from the PG Board is not connected properly to the drive.	Make sure that the wiring is connected properly.
Pulse output from the PG Board is not compatible with the input to the drive.	Check the settings on both the PG Board and the drive. Certain models of drives require turning off the power in order to validate the new settings.
The maximum frequency of the general pulse output is not set properly.	Make sure that the settings comply with the drive's specifications.
The control mode for the drive is not set at the position control mode.	Check the settings.
Either the output from the drive signal to the motor or receiving the pulse input from the PG Board is prohibited at the drive settings.	Check the signal settings at the drive.
Either the torque limit signal or speed limit signal is input to the drive.	Check the signal settings at the drive.
The gain setting for the drive is not appropriate for the load.	Set the gain properly by referring to the drive's manual.
The drive is outputting the alarm signal.	Find out the cause and cancel that situation by referring to the drive's manual.

<b>Rotation of motor is unstable. Motor rotation position varies.</b>	
<b>Cause</b>	<b>Solution</b>
The origin sensor is too close to the encoder Z phase.	Adjust the origin sensor position.
The setting for the maximum frequency of the generated pulse is not appropriate.	Set the maximum frequency value within the range specified in the drive's specifications.
Excessive power swing at the stepper motor.	Find out the cause of the overload to cancel the situation or run with lower speed / acceleration.
The wiring that connects the PG Board to the drive is too long.	Keep the wiring as short as possible. (The length recommended is 1.5 meters or shorter.)
There is a powerful noise source in the surrounding area.	See the section <i>2.4.1 Minimizing Noise Interference</i> . Also refer to the related sections for the wiring and noise countermeasures in the drive's manual.
There is no check at the Clear MCAL check box on the Calibration tab of the PG Robot Configuration dialog when the servo motor is used.	Refer to the section <i>3.4.5 Calibration Parameters</i> . Check Clear MCAL for each joint that uses a servo motor.
The [Clear MCal] may be set to "False" in the System Configuration   Robot when you use the servo motor.	Refer to the section <i>3.2.3 PG parameter Joint</i> and set the [Clear MCal] to "True".

<b>Error 4004, Event waiting error with the Motion Control Module occurs</b>	
<b>Cause</b>	<b>Solution</b>
The servo motor is oscillating and the position completion signal is not output.	Adjust the gain to prevent the servo motor from oscillating.
The positioning cannot be carried out because the servo motor's joint is interfering with an obstacle. It is possible that the servo motor's enforcing operation obstructs the positioning.	Connect the $\overline{\text{DEND}}$ input to GND to disable wait for positioning.

<b>Error 4083, MCAL did not complete in time. occurs</b>	
<b>Cause</b>	<b>Solution</b>
The calibration of each joint was not completed within 120 seconds during MCAL execution.	Refer to the section <i>3.2.2 PG Parameters</i> <i>3.3.4 [Mcal Order]</i> and check the settings of the Manipulator.

## 6. Maintenance Parts List

Specify the code when ordering maintenance parts.

Parts Name	Code	Old Code	Note
PG (Pulse Generator) board	R12NZ900A8	R12N748011	
PG board cable	R12NZ900BB	R12R500PLS004	
Terminal block	R12NZ900B6	R12R500DIO005	
PG board connector	R12NZ900H2	R12R500PLS005	
Pulse Generating Kit	R12NZ900A9	R12N748041	PG (Pulse Generator) board Plug, Cover PG board cable Connector (2) Terminal block (2)